

Surname	Centre Number	Candidate Number
Other Names		0



GCSE

C300U10-1



MATHEMATICS – Component 1
Non-Calculator Mathematics
FOUNDATION TIER

THURSDAY, 2 NOVEMBER 2017

– MORNING

2 hours 15 minutes

ADDITIONAL MATERIALS

The use of a calculator is not permitted in this examination.
A ruler, protractor and a pair of compasses may be required.

INSTRUCTIONS TO CANDIDATES

Use black ink or black ball-point pen.
You may use a pencil for graphs and diagrams only.
Write your name, centre number and candidate number in the spaces at the top of this page.
Answer **all** the questions in the spaces provided.
If you run out of space, use the continuation page at the back of the booklet, taking care to number the question(s) correctly.
Take π as 3.14.

INFORMATION FOR CANDIDATES

You should give details of your method of solution when appropriate.
Unless stated, diagrams are not drawn to scale.
Scale drawing solutions will not be acceptable where you are asked to calculate.
The number of marks is given in brackets at the end of each question or part-question.
You are reminded of the need for good English and orderly, clear presentation in your answers.

For Examiner's use only		
Question	Maximum Mark	Mark Awarded
1.	7	
2.	7	
3.	5	
4.	4	
5.	5	
6.	5	
7.	4	
8.	10	
9.	6	
10.	4	
11.	3	
12.	7	
13.	7	
14.	5	
15.	4	
16.	4	
17.	5	
18.	2	
19.	4	
20.	5	
21.	5	
22.(a)	2	
22.(b)(c)	5	
23.	5	
Total	120	

C300U101
01

1. (a) Work out $3 + 4 \times 5$.

[1]

.....

.....

.....

(b) Write down a fraction that is equivalent to $\frac{4}{36}$.

[1]

.....

.....

(c) Write $\frac{11}{20}$ as a percentage.

[1]

.....

.....

(d) Find $\frac{3}{7}$ of 14.

[2]

.....

.....

.....

(e) Work out $\frac{30 \times 0.5}{5}$.

[2]

.....

.....

.....

2. (a) Points A and B are on the circumference of the circle with centre O .

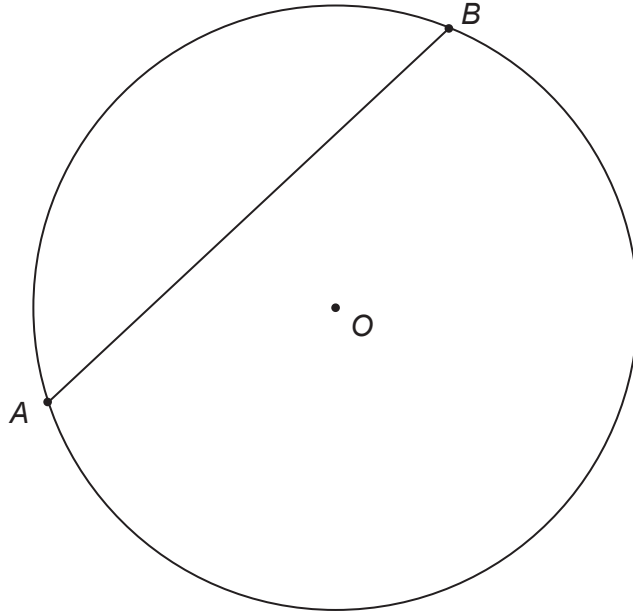

- (i) Circle the name of the straight line AB .

[1]

radius

chord

circumference

tangent

arc

- (ii) AC is a diameter of the circle.
Draw this diameter on the circle above.
Label the point C .

[2]

- (b) Calculate the size of each of the angles w , x and y .

[4] Examiners only

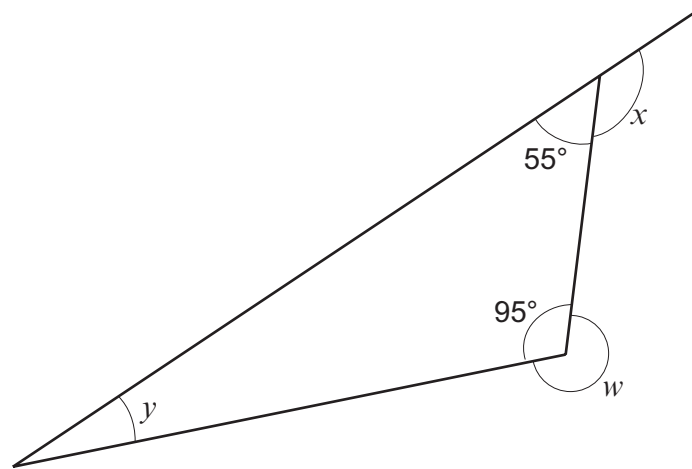

Diagram not drawn to scale

.....

.....

.....

.....

.....

.....

.....

.....

$w = \dots\dots\dots^\circ$, $x = \dots\dots\dots^\circ$; $y = \dots\dots\dots^\circ$

C300U101
05

3. (a) Write the following numbers in order of size, starting with the smallest number.

[2]

$$\frac{3}{4}$$

0.08

76%

.....

.....

.....

.....

.....

(b) A packet of mixed wildflower seeds contains 200 seeds.

- $\frac{1}{4}$ of the seeds are poppies.
- 30% of the seeds are daisies.
- The rest of the seeds are cornflowers.

How many of the seeds are cornflowers?

[3]

.....

.....

.....

.....

.....

.....

4. Theo and Anya are buying food and drink for a picnic.

- (a) Theo buys a salad and five identical packs of chicken sandwiches.
The salad costs £3.
Theo's total bill is £18.03.

Theo says,
'This bill must be wrong.'

Explain why Theo is correct.

[1]

.....

.....

.....

.....

(b)

Cold drink deal.
Buy 1 cola
get
1 lemon fizz free.



Anya needs 4 bottles of cola and 5 cans of lemon fizz.
A can of lemon fizz costs £1.05.
She pays £9.45.

How much does a bottle of cola cost?

[3]

.....

.....

.....

.....

.....

5. (a) Draw a hexagon that has exactly one line of symmetry on the grid below. [2]

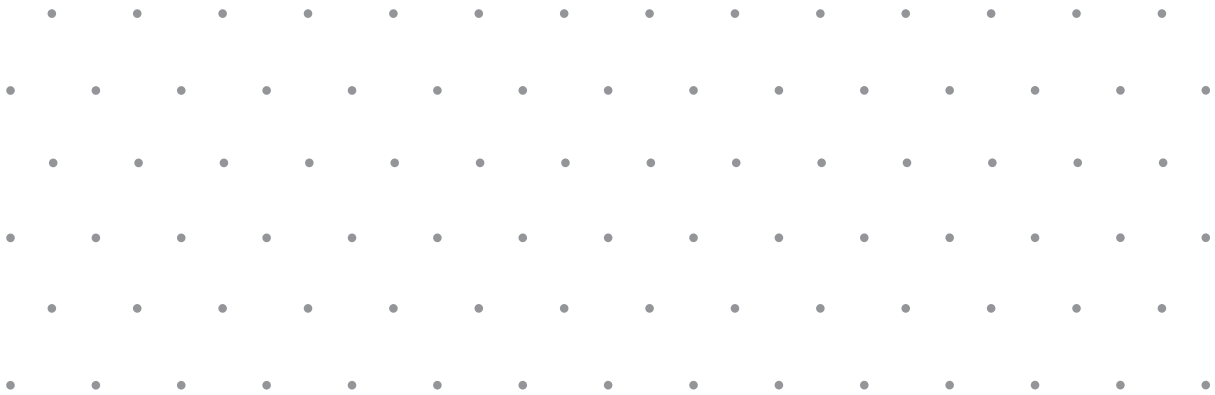

- (b) The diagram accurately shows two lines AB and BC .
These lines are part of a quadrilateral, $ABCD$.
Point D is missing.

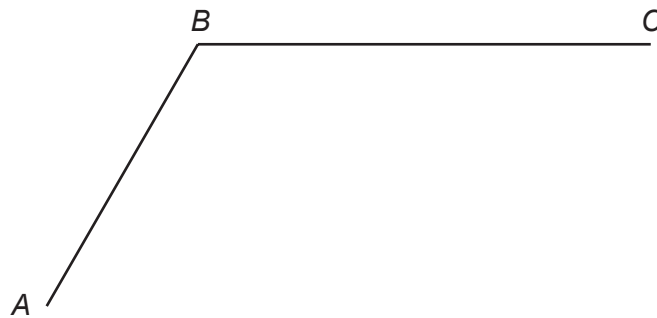

- (i) Use this information to complete the quadrilateral $ABCD$:
 AD is parallel to BC ,
Angle $BCD = 60^\circ$,
 CD is the same length as AB . [2]

- (ii) Write down the name of the quadrilateral $ABCD$. [1]

.....

6. (a) Here is a number machine.

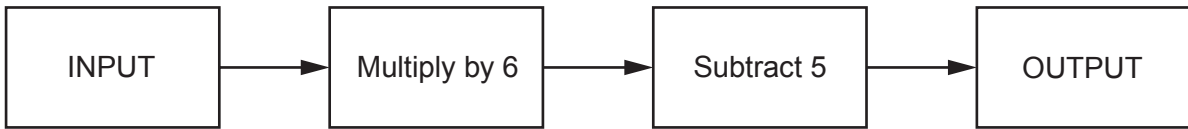

(i) The input is 9.
What is the output?

[1]

.....

(ii) The input is -2.
What is the output?

[1]

.....

.....

(iii) The output is 19.
What is the input?

[1]

.....

.....

(b) Here is a different number machine.

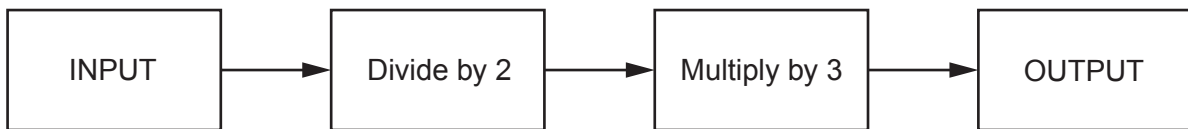

The input is always a positive whole number for this number machine.

Paul says,

'The output is a whole number.'

Explain clearly why Paul's statement is sometimes true but not always true.
Use examples to explain your answer.

[2]

.....
.....
.....
.....
.....

7. (a) There are 4 rowers in a boat.
The mode and median of their shoe sizes are both 11.
The range of their shoe sizes is 4.
One of the rowers has size 13 shoes.

What is the shoe size of each rower?

[2]

.....

.....

.....

.....

.....

.....

.....

.....

(b) A rowing club uses a bar chart to record the number of teams of rowers they have for each type of boat.

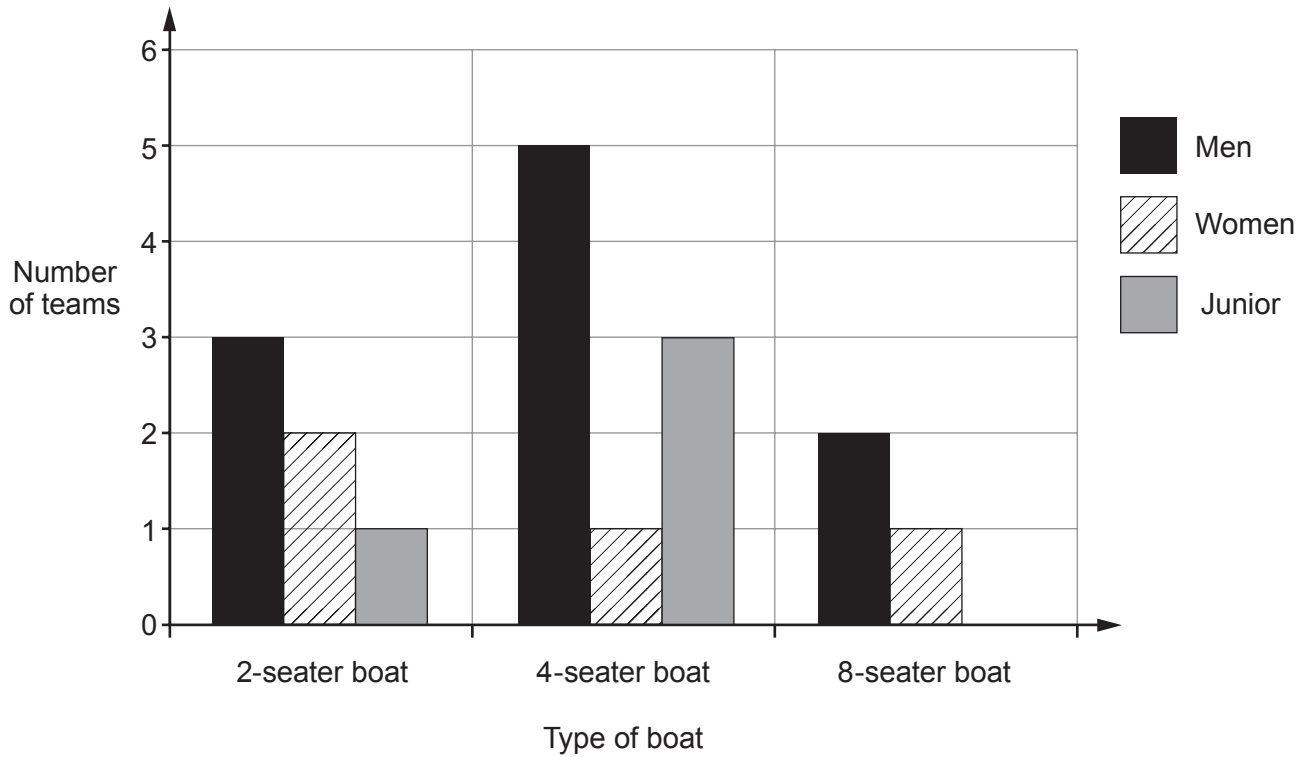

(i) How many teams does the rowing club have in total? [1]

.....

.....

.....

.....

(ii) Rona is a junior rower at the club.
 What is the probability that Rona rows in a junior 8-seater boat? [1]

.....

8. Mary owns a café.

(a) Mary's lunch menu is for two courses, a main course and a dessert.

Lunch Menu - 2 courses for £10	
Main Courses	Desserts
Fish	Apple pie
Curry	Toffee pudding
Pizza	
Salad	

(i) How many different two-course meals is it possible to order for lunch?
You must show all your working.

[2]

.....

.....

.....

.....

.....

.....

.....

.....

.....

Number of different two-course meals

(ii) Mary says,

'If a customer has a dessert, the probability they choose apple pie is $\frac{1}{2}$
because there are 2 desserts.'

Explain why Mary may not be correct.

[1]

.....

.....

.....

(b) Mary also serves drinks.

Drinks Menu			
Hot drinks	Tea or Coffee	per cup	£2
Cold drinks	Juice or Milkshake	per glass	£3

One Friday lunchtime, 40% of her customers order a hot drink.

(i) What proportion of her customers do **not** order a hot drink? [1]

(ii) On this Friday lunchtime, Mary has 120 customers.
Each customer orders one drink.

How much money does Mary take from selling drinks? [4]

(c) Mary is thinking about selling smoothies for £1.75 per glass.
The smoothie would cost Mary £1 per glass to make.

How many smoothies would Mary need to sell, to make £15 profit just from selling smoothies? [2]

9. Laura rides her bicycle along a course. She starts at point A , marked on the scale diagram below. The scale of the diagram is 1 cm represents 0.8 km.

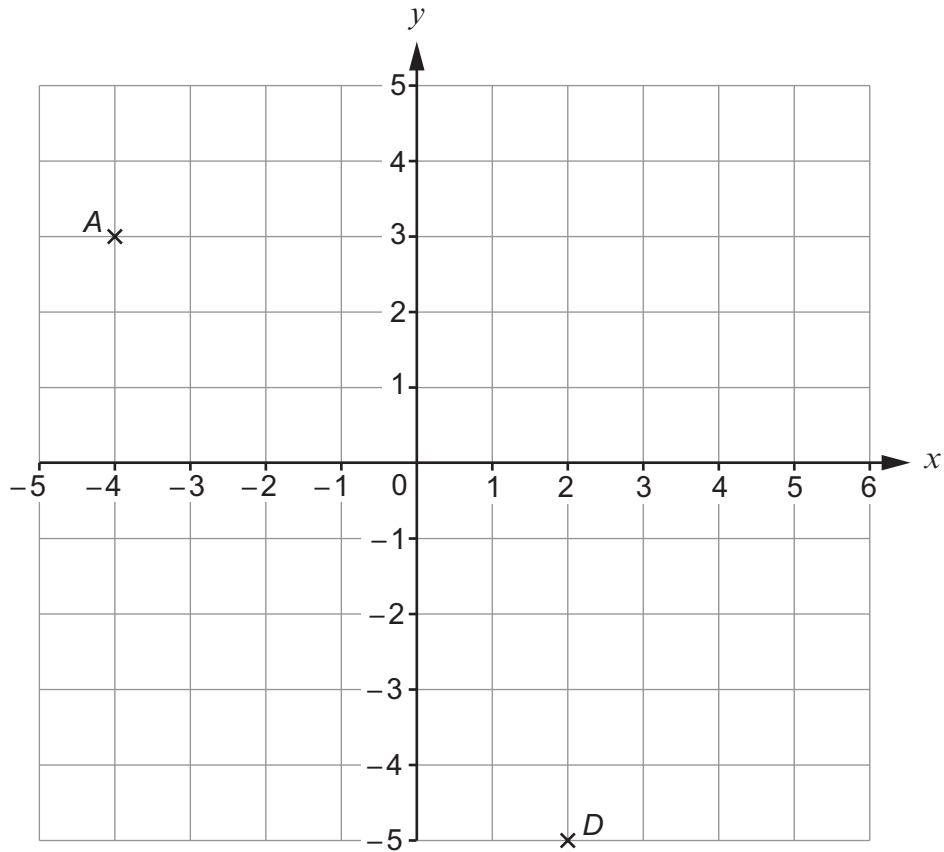

- (a) Write down the coordinates of point A . [1]
-

- (b) Laura rides to point B at $(1, 3)$, then to point C at $(4, -2)$ and then to point D .
Mark the positions of point B and point C on the grid. [2]

- (c) Laura takes 20 minutes to ride from point *D* directly back to point *A*.
Her target speed for this part of the journey is 24 km/h.
The scale of the diagram is 1 cm represents 0.8 km.

Does Laura meet her target speed?

Yes No

You must show all your working.

[3]

.....

.....

.....

.....

.....

.....

.....

.....

.....

.....

10. (a) Work out $5^2 + \sqrt{49}$.

[2]

.....

.....

.....

.....

(b) By first rounding each number in the calculation to 1 significant figure, **estimate** the value of $\frac{42 \times 96}{11}$.

You must show all your working.

[2]





.....

.....

.....

.....

11. (a) The pictogram represents the number of people using a breakfast club on certain weekdays.

Monday	
Tuesday	
Wednesday	
Thursday	
Friday	

Key:  stands for 4 people

Comment on the design of this pictogram.

[1]

.....

.....

- (b) The line graph shows the trend of the average monthly sales of a toy company in thousands of pounds.

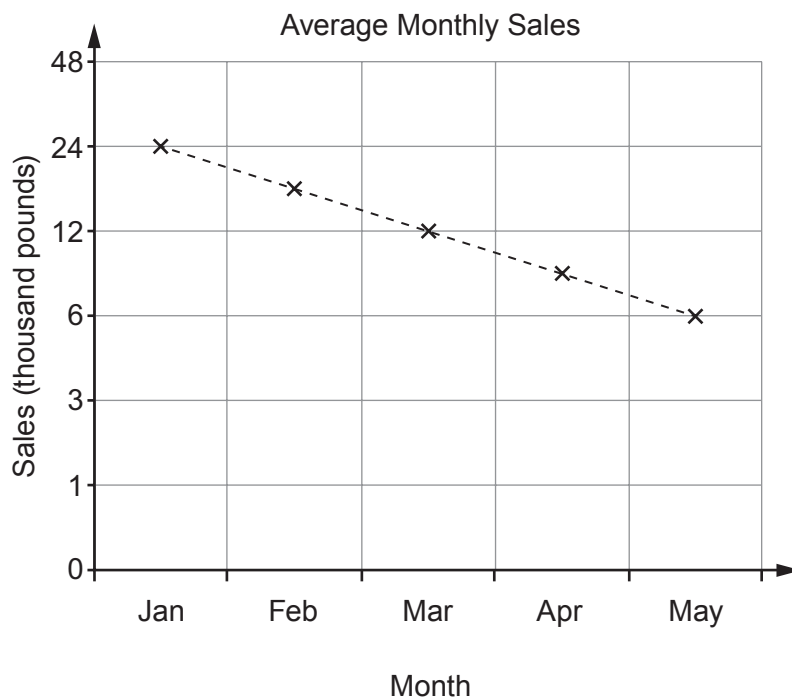

- (i) A deliberate error has been made when drawing this line graph.

Explain what error has been made.

[1]

- (ii) Comment on the impact of this error.

[1]

- (b) Archie raised a total of £800 from two investors.
These investors were paid 5% per year simple interest on the amount they invested.

Complete the table.

[4]

Investor	Amount invested (£)	Number of years	Total Interest (£)
Fred	500	3	
Ceri	300		60

.....

.....

.....

.....

.....

.....

.....

.....

13. This formula can be used to find the time it takes to cook a joint of meat.

$$t = 25p + 20$$

where t is the time in minutes,
 p is the mass of the meat in pounds.

- (a) When $p = 0$, $t = 20$.

Explain whether the formula is valid when $p = 0$.

[1]

.....
.....

- (b) (i) Complete the table below, then draw the graph of $t = 25p + 20$ for $1 \leq p \leq 4$ on the graph paper opposite. [3]

p	1	2	3	4
t				

.....
.....
.....
.....

- (ii) Find the mass of a joint of meat that takes 1 hour 30 minutes to cook.

[1]

.....
.....

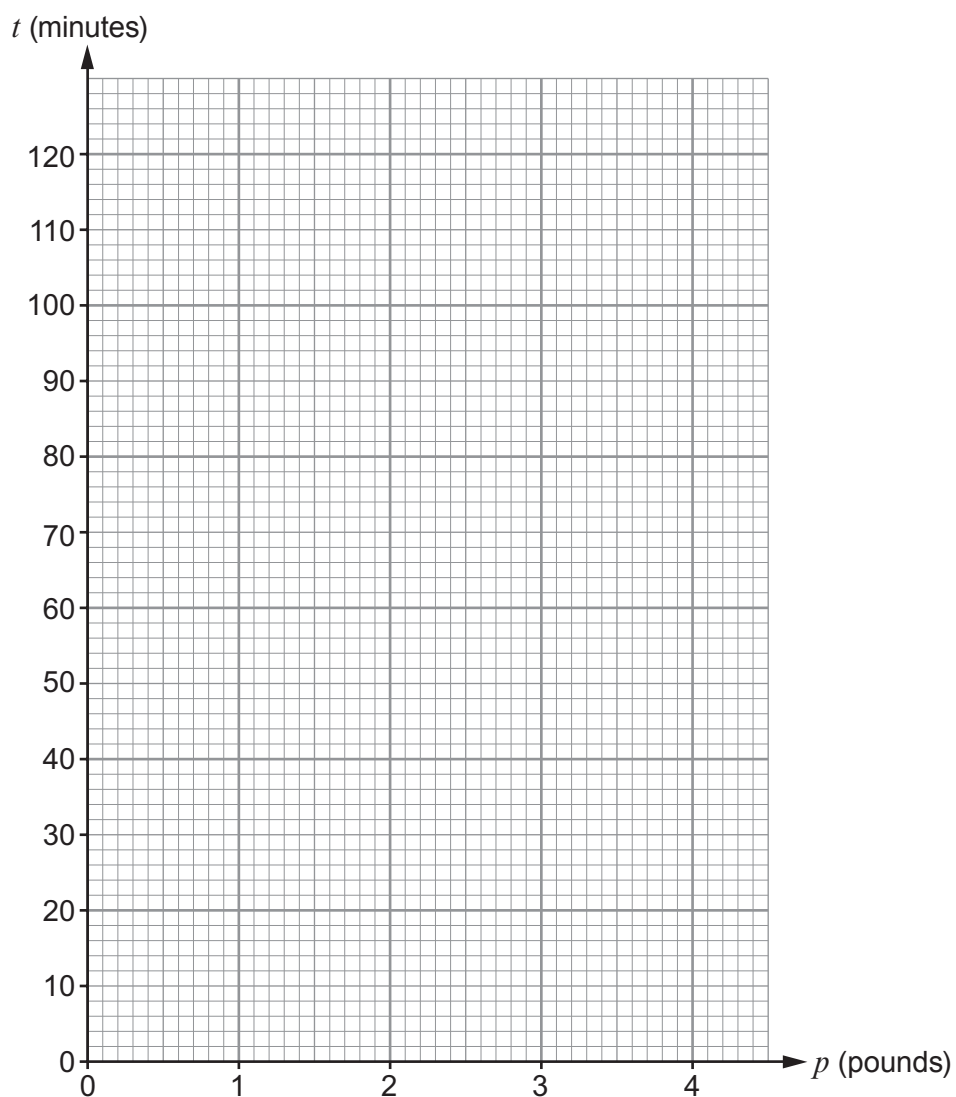

- (c) Tasniah wants to cook a joint of meat that has a mass of 2 pounds. She also wants to bake some potatoes.

She knows the potatoes will take $\frac{3}{4}$ of an hour to bake.

When the meat has finished cooking, it must be taken out of the oven and left for 15 minutes before it is ready to be served.

She wants to serve the potatoes at the same time as the meat.

How long after Tasniah puts the meat in the oven should she put the potatoes in the oven to bake? [2]

.....

.....

.....

.....

.....

14. (a) Which scatter diagram would show the relationship between the age and height of a child? Put a tick in the box below the scatter diagram. [1]

Graph 1

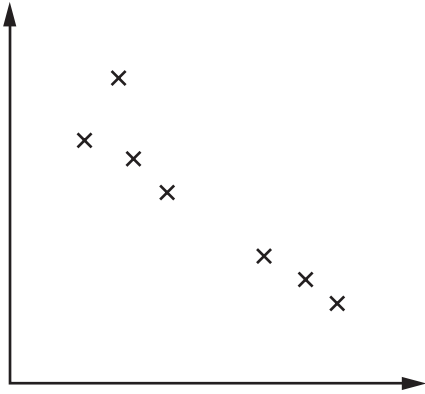

Graph 2

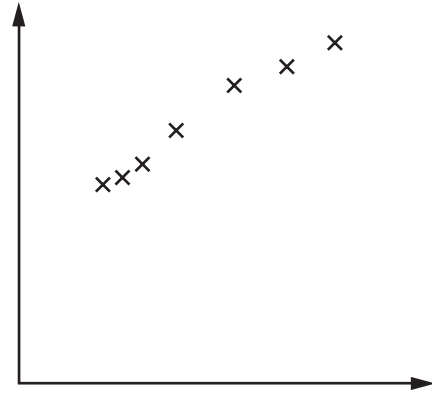

Graph 3

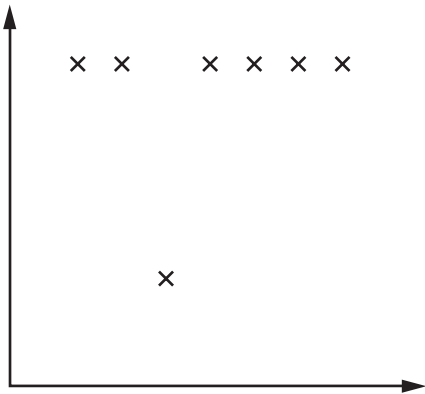

Graph 4

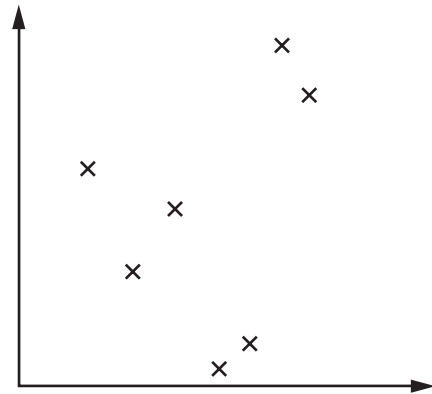

(b) The scatter diagram shows the exam results in maths and science of a class of GCSE students.

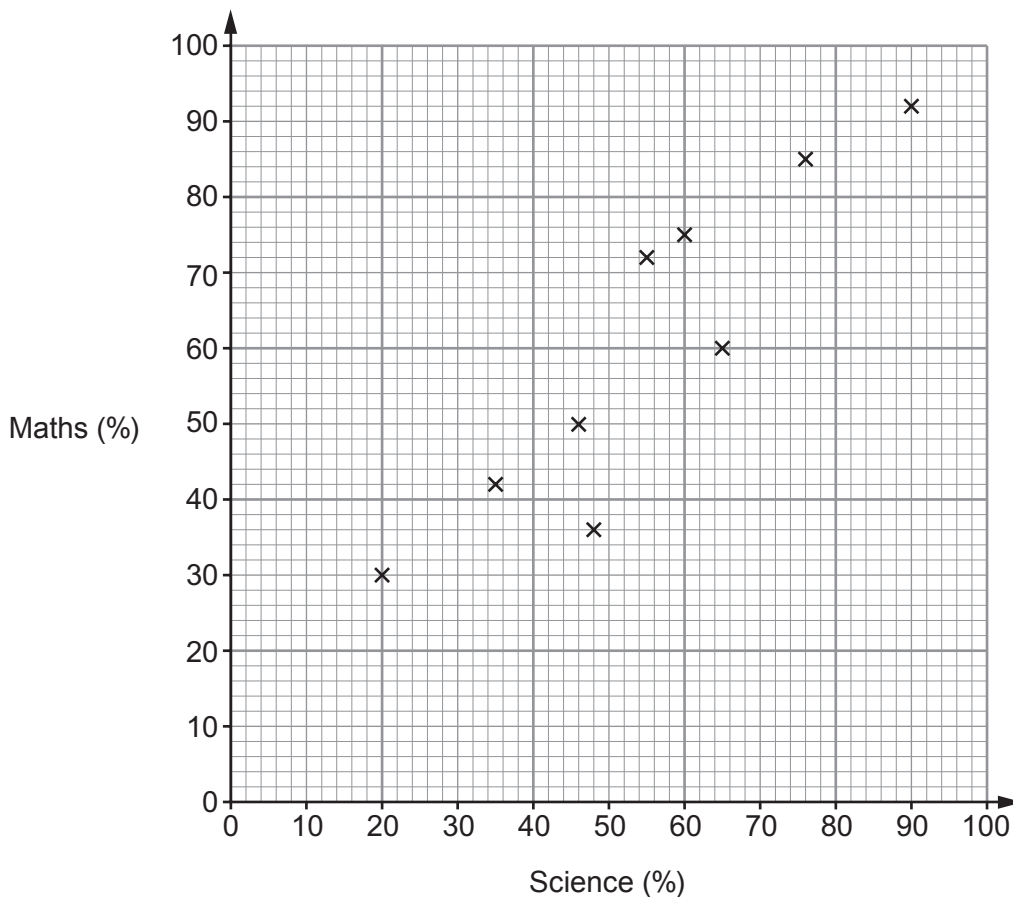

(i) Two students had higher marks in science than they did in maths.

Write down the maths and science marks of these two students. [2]

Student 1 Science mark

 Maths mark

Student 2 Science mark

 Maths mark

(ii) One of the students from the class is chosen at random.
Find the probability that this student scored more than 70% in maths. [2]

.....

.....

.....

15. (a) Write down the next number in this sequence. [1]

1 8 27 64

.....

.....

.....

(b) The n th term of a sequence is $8n - 16$.

(i) Write down the first 3 terms of this sequence. [2]

.....

.....

.....

.....

(ii) The n th term of a different sequence is n^2 .

Sasha says,

'The 4th term of the sequence with n th term $8n - 16$ is the same as the 4th term of the sequence with n th term n^2 .'

Is Sasha correct?

Yes

No

Justify your answer. [1]

.....

.....

.....

.....

.....

16. $\mathbf{p} = \begin{pmatrix} 5 \\ 4 \end{pmatrix}$ and $\mathbf{q} = \begin{pmatrix} 1 \\ -1.5 \end{pmatrix}$

(a) Work out the column vector $2\mathbf{p} - \mathbf{q}$.

[2]

.....

.....

.....

.....

(b) The grid shows the vector \mathbf{q} .

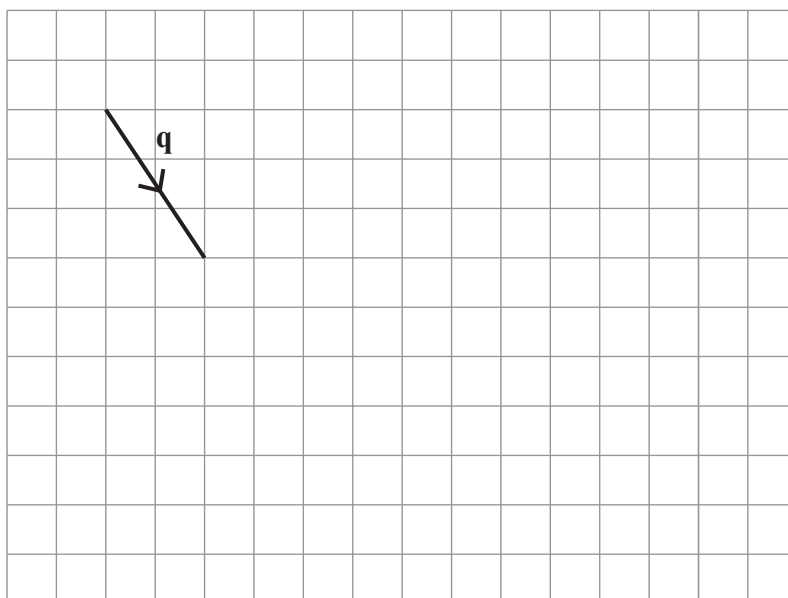

On the same grid, draw the vector $-3\mathbf{q}$.

[2]

17. (a) Tina is carrying out a survey to find out how people use their mobile phones.

(i) Here is a question from her survey.

What do you use your mobile phone to do?
Tick (✓) one box.

Text Call Take a photo

State one criticism of this question.

[1]

.....

.....

.....

(ii) Here is a different question from her survey.

How often do you use your mobile phone?
Tick (✓) one box.

All the time A lot Not much Never

State one criticism of this question.

[1]

.....

.....

.....

(b) Tina surveyed 205 students about the cost of their monthly phone bills. The table shows this information.

	Number of students	Lowest bill	Mean bill	Highest bill
Pay-as-you-go	100	£5	£12.75	£70
SIM only	100	£15	£16.25	£18
Monthly contract	5	£28	£40	£60

(i) Comment on how reliable the data about Monthly contracts are likely to be. [1]

.....

.....

.....

(ii) **Using the data in the table**, Tina compares the cost of Pay-as-you-go with the cost of SIM only. Tina says that students who use Pay-as-you-go have both the lowest and highest bills.

Make further comments to explain why Tina may think

- SIM only is a better deal,
- Pay-as-you-go is a better deal.

[2]

Complete each of the following statements.

SIM only could be a better deal because

.....

.....

Pay-as-you-go could be a better deal because

.....

.....

18. Using a ruler and a pair of compasses, construct the perpendicular from A to the line BC . You must show your construction arcs. [2]

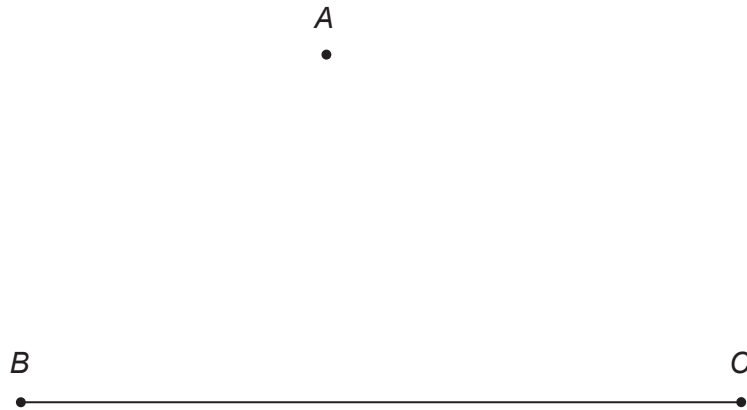

19. (a) Expand and simplify $(x - 5)(x + 2)$. [2]

.....

.....

.....

- (b) Simplify $3a^2 \times 6a^{-1}$. [2]

.....

.....

.....

20. (a) The variables x and y are connected by the equation $y = \frac{25}{x}$.

(i) Circle the correct statement.

[1]

x is inversely proportional to 25

x is directly proportional to y

y is inversely proportional to x

y is directly proportional to x

(ii) Find the value of x when $y = 100$.

[2]

.....

.....

.....

(b) The distance-time graph shows the start of a journey.

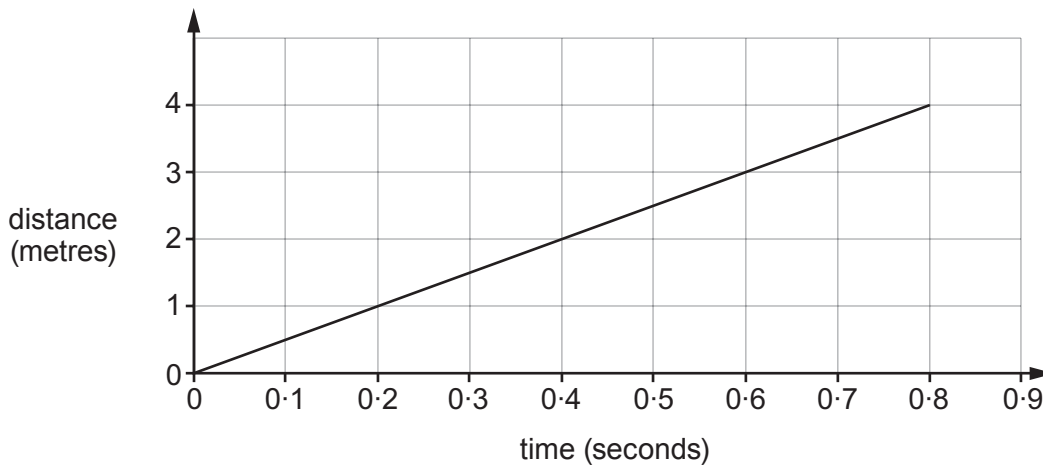

Work out the speed of this part of the journey in metres per second.

[2]

.....

.....

.....

.....

.....

21. (a) (i) Simplify $15\pi - \pi$.

[1]

.....

.....

- (ii) Work out $12\pi \div 3\pi$.

[1]

.....

.....

- (b) The diagram shows a circle inside a square.
The circumference of the circle touches all four sides of the square.

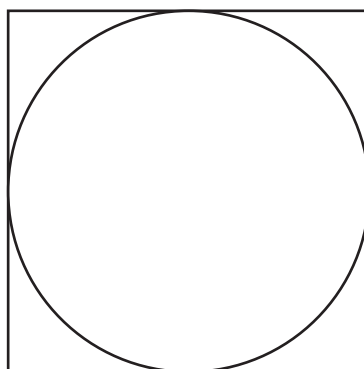

Diagram not drawn to scale

The perimeter of the square is 24 cm.

Work out the area of the circle.
Give your answer as a multiple of π .

[3]

.....

.....

.....

.....

.....

.....

.....

22. (a) Work out $\frac{6}{7} - \frac{2}{5}$.

[2]

.....

.....

.....

.....

(b) Three two-digit integers a , b and c are in the ratios

$$a : b = 4 : 5 \quad \text{and} \quad b : c = 7 : 11.$$

Find the integers a , b and c .

[3]

.....

.....

.....

.....

.....

.....

.....

.....

$$a = \dots\dots\dots \quad b = \dots\dots\dots \quad c = \dots\dots\dots$$

(c) A length of string has been cut into two pieces in the ratio 3 : 5.
The longer piece measures 205 cm.

What was the original length of the string?

[2]

.....

.....

.....

.....

23. (a) In a warehouse, 4 workers can load 5 tonnes of goods into a vehicle in 3 hours.

How long would it take 6 workers to load 10 tonnes of goods into a vehicle?
You may assume that all workers work at the same rate.

[3]

.....

.....

.....

.....

.....

.....

.....

.....

.....

.....

.....

.....

.....

.....

.....

.....

.....

.....

.....

.....

.....

.....

.....

(b) State one other assumption you have made in your answer to part (a).
How would your answer to part (a) change if this assumption were not correct?

[2]

.....

.....

.....

.....

.....

.....

.....

.....

.....

.....

.....

.....

.....

.....

.....

.....

.....

.....

.....

.....

.....

.....

END OF PAPER