

Answer **all** the questions.

1 A student rolls two fair four-sided dice each numbered 1, 2, 3 and 4. They add the two scores together.

(a) Complete the sample space diagram to show the possible outcomes from the dice.

		Second dice			
		1	2	3	4
First dice	Total				
	1	2	3	4	5
	2	3	4	5	6
	3	4	5	6	7
4	5	6	7	8	

✓7+
✓All

(b) Find the probability that the student gets an even total.

$$\frac{8}{16}$$

[2]

✓OE

(b) [1]

(c) Find the probability that the student gets the same score on each dice.

$$\frac{4}{16}$$

✓OE

(c) [1]

2 The circumference of a circle is 23 cm.

Show that the area of the circle is 42.1 cm², correct to 3 significant figures.

[4]

$$2\pi r = 23$$

$$r = \frac{23}{2\pi}$$

✓

$$\text{Area} = \pi \times \left(\frac{23}{2\pi}\right)^2 = 42.096\dots$$

$$= 42.1 \text{ cm}^2 \text{ (3sf)}$$

✓✓

- 3 Light from the Sun travels 1 kilometre in 3.3×10^{-6} seconds.
The distance from the Sun to the Earth is 1.5×10^8 kilometres.

How long does it take light to travel from the Sun to the Earth?
Give your answer in minutes and seconds.

$$T = 1.5 \times 10^8 \times 3.3 \times 10^{-6} \quad \checkmark \checkmark$$

$$= 495 \text{ secs} \quad \checkmark$$

$$= 8 \text{ mins } 15 \text{ s}$$

8 minutes 15 seconds [4] \checkmark

- 4 You are given that

$$\frac{10a^k \times a^8}{ma^5} = \frac{2a^7}{5}$$

where k and m are integers.

Find the value of k and the value of m .

$$k + 8 - 5 = 7 \quad \checkmark$$

$$k = 4 \quad \checkmark$$

$$\frac{10}{m} = \frac{2}{5} \quad \checkmark$$

$$50 = 2m \quad \checkmark$$

$$25 = m$$

$k = 4$ and $m = 25$ [4]

- 5 In each row of the table there are two triangles.

State whether the two triangles are congruent or not.

If they are congruent state a reason from SSS, SAS, ASA or RHS.

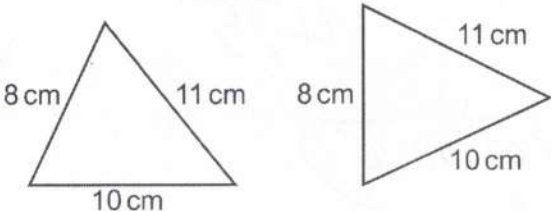
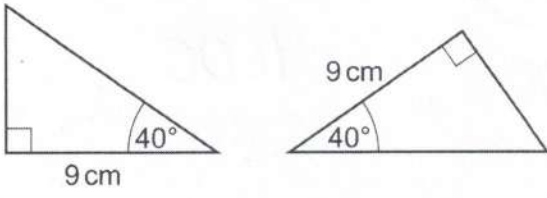
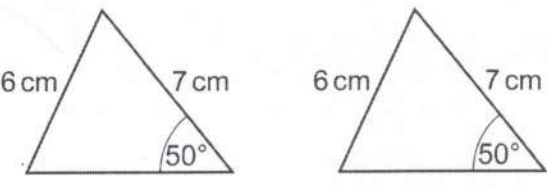
Triangles	Congruent (yes/no)	Reason (SSS/SAS/ASA/RHS)
<p style="text-align: center;">Not to scale</p> 	Y	SSS
<p style="text-align: center;">Not to scale</p> 	Y	ASA
<p style="text-align: center;">Not to scale</p> 	N	"ignore"

[3]

- 6 The mass of a stone is 680g.
The density of the stone is 1.6 g/cm^3 .



- (a) Work out the volume of the stone.

$$V = \frac{680}{1.6}$$



425



- (b) Write 1.6 g/cm^3 in kg/m^3

g \rightarrow kg
 $\div 1000$
"dilutes"

"more contained"
 $\text{cm}^3 \rightarrow \text{m}^3$
 $\times 1,000,000$
so 1.6×1000

(a) cm^3 [2]

(b) kg/m^3 [1]

1600



- 7 (a) Multiply out and simplify.

$$(x-4)(x+5)$$

$$= x^2 + 5x - 4x - 20$$



(a) [2]

$$x^2 + x - 20$$



- (b) Factorise.

$$x^2 - 25$$

(b) [1]

$$(x+5)(x-5)$$



- 8 1600 fish are released into a new lake which has no fish.
The number of fish is expected to increase by 5% each year.

- (a) The table shows the expected number of fish in the lake at the end of 1 year and at the end of 2 years.

Complete the table.

Round your answers to the nearest integer.

$$1764 \times 1.05 = 1852.2 \quad \checkmark$$

$$1852 \times 1.05 = 1944.6$$

Years after release	0	1	2	3	4
Expected number of fish	1600	1680	1764	1852	1945

[3]

- (b) Use the table to draw a suitable graph to show the expected number of fish in the lake.

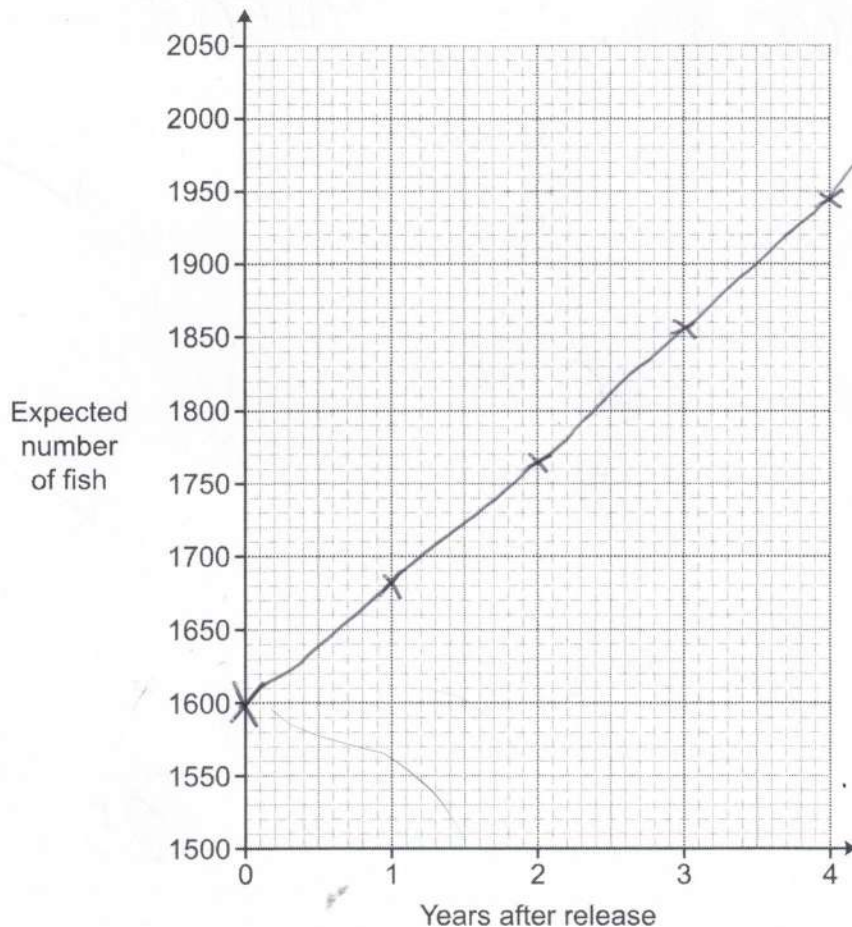

[3]

- (c) A maximum of 2000 fish can live in the lake.

What effect would you expect this to have on the shape of your graph after 4 years?

Increases until 2000 then levels off

[2]

- 9 A garage is trying to sell a car.
The price of the car is normally £18000.
In a sale, the price of the car is reduced by 30%.
As a special offer, the sale price is then reduced by $r\%$.
The special offer price is £9450.

Find the value of r .

You must show your working.

$$18000 \times 0.7 = 12600$$

$$12000 \times y = 9450$$

$$y = \frac{9450}{12600}$$

$$y = 0.75$$

$$= 75\%$$

$$100 - 75 = 25$$

$$r = 25$$

[5]

- 10 The diagram shows a triangular prism and a cube.
The ends of the prism are right-angled triangles with base 16 cm and height 12 cm.
The prism is 18 cm long.

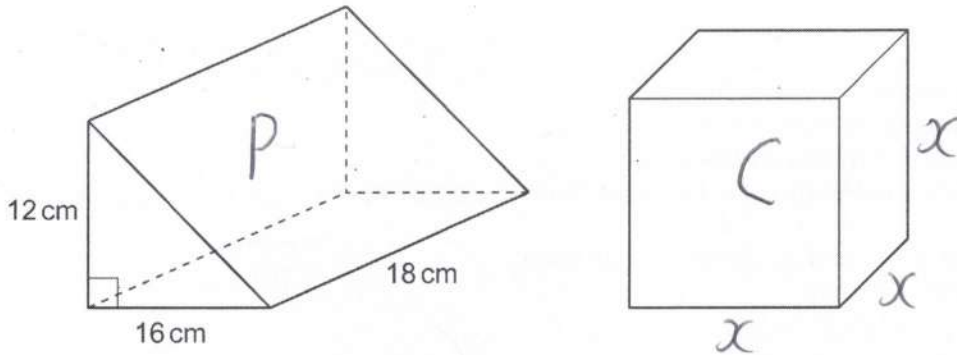

The volume of the prism is equal to the volume of the cube.

Find the **surface area of the cube**.
You must show your working.

$$\text{Vol } P = \frac{1}{2} \times 16 \times 12 \times 18 = 1728 \quad \checkmark$$

$$\text{Vol } C = x^3 = 1728 \quad \checkmark$$

$$x = \sqrt[3]{1728} = 12 \quad \checkmark$$

$$\text{SA } C = 6 \times 12^2 \quad \checkmark$$

864

..... cm² [6] ✓

- 11 Amir, Beth and Charlie work in a cafe. Customers give spare change as tips. At the end of each week, Amir, Beth and Charlie share the total amount of tips between them in the ratio matching the number of hours they worked that week.

This week:

- Amir's share of the tips was £25.40.
- Beth worked twice as many hours as Amir.
- Charlie worked 5 more hours than Amir.
- The total hours worked by Amir, Beth and Charlie was 85 hours.

Calculate the total amount of tips received this week. You must show your working.

A	B	C	
25.40			
x	$x+5$	$2x$	$= 85 \quad \checkmark$

$$4x + 5 = 85 \quad \checkmark$$

$$4x = 80$$

$$x = 20 \quad \checkmark$$

$$\checkmark \quad \frac{25.40}{20} \times 85 \quad \checkmark$$

£ 107.95 \checkmark

..... [6]

- 12 A student has a spinner with sectors numbered 1, 2, 3 and 4.

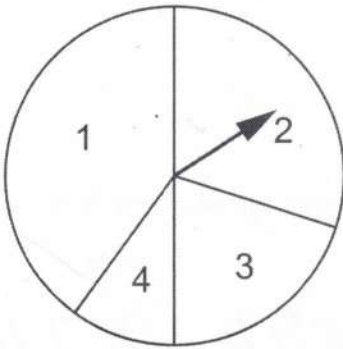

The table shows the probability of each score.

Score	1	2	3	4
Probability	0.4	0.3	0.2	0.1

The student spins the spinner twice.

Calculate the probability that the student gets the same score on each spin.

$$\begin{aligned}
 P(\text{Same}) &= 1,1 + 2,2 + 3,3 + 4,4 \quad \checkmark \\
 &= 0.4^2 + 0.3^2 + 0.2^2 + 0.1^2 \quad \checkmark\checkmark
 \end{aligned}$$

0.3 ✓

..... [4]

- 13 A car registration plate has two letters, a number from 10–99 and three letters.
For example:

AB56 CDE

The letters I and O are not used, leaving 24 possible letters.

Show that there are approximately 720 million possible car registration plates of this form. [4]

$$\begin{aligned}
 & \checkmark \quad \checkmark \quad \checkmark \\
 & 24 \times 24 \times 90 \times 24 \times 24 \times 24 \\
 & = 716,636,160 \quad \checkmark \\
 & \approx 720,000,000
 \end{aligned}$$

- 14 Sketch the graph of $y = \cos x - 1$ for $0^\circ \leq x \leq 720^\circ$.

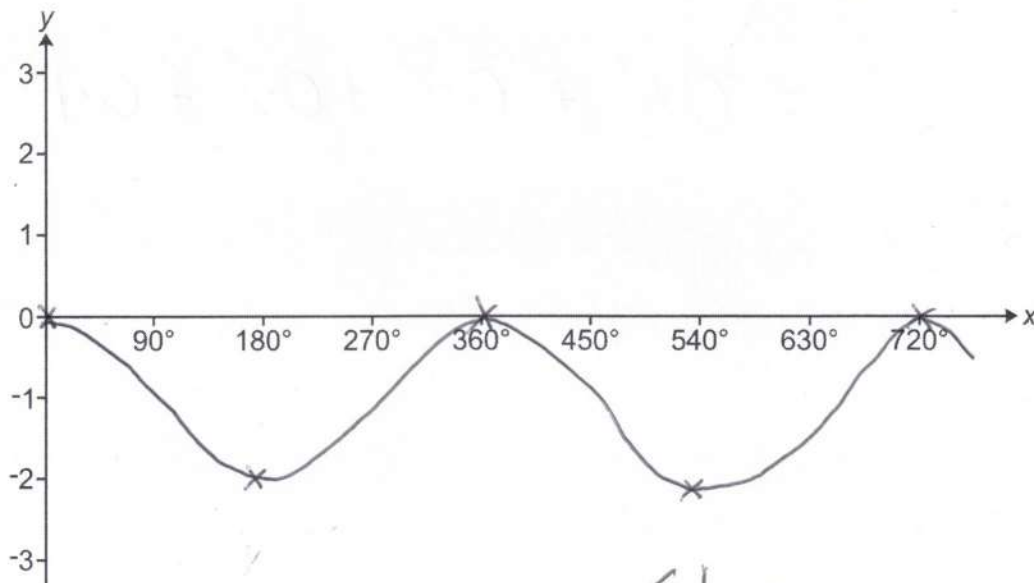
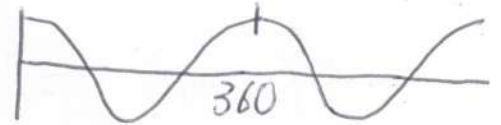

✓ shape

✓ 0
✓ -2

✓ 360, 720

[3]

- 15 80 cyclists take part in a race.
A summary of their times is shown in the table.

Time (t minutes)	Frequency
$20 < t \leq 25$	5
$25 < t \leq 30$	15
$30 < t \leq 35$	24
$35 < t \leq 40$	25
$40 < t \leq 45$	7
$45 < t \leq 50$	4

- (a) Complete the cumulative frequency table.

Time (t minutes)	Cumulative frequency
$t \leq 25$	5
$t \leq 30$	20
$t \leq 35$	44
$t \leq 40$	69
$t \leq 45$	76
$t \leq 50$	80

✓ 4
✓ All

[2]

(b) Draw the cumulative frequency graph to show the information.

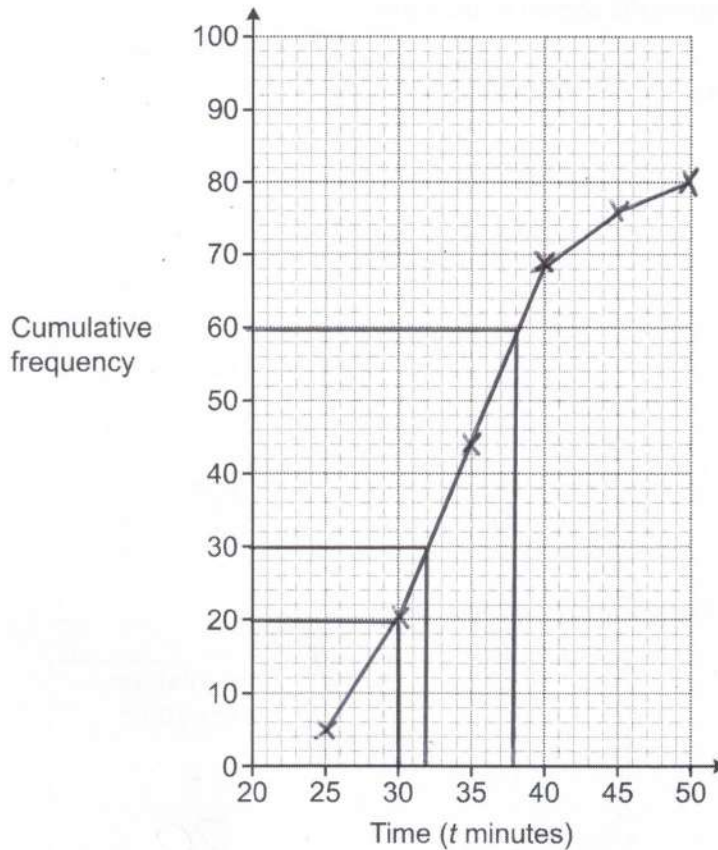

[3]

(c) Reece makes two comments about the times taken to complete the race.

For each comment, decide if Reece is right or wrong and give a reason for your answer.

(i) $\frac{3}{4}$ of the 80 cyclists took more than 30 minutes to complete the race.

Reece is correct because 20th person took about 30 mins so 21 → 80 took more (next 60) ✓

..... [2]

(ii) The longest time that any of the 80 cyclists took to complete the race must have been 50 minutes.

Reece is wrong because it could be anywhere between 45 → 50 ✓

..... [1]

16 Frankie sketches this quadratic graph.

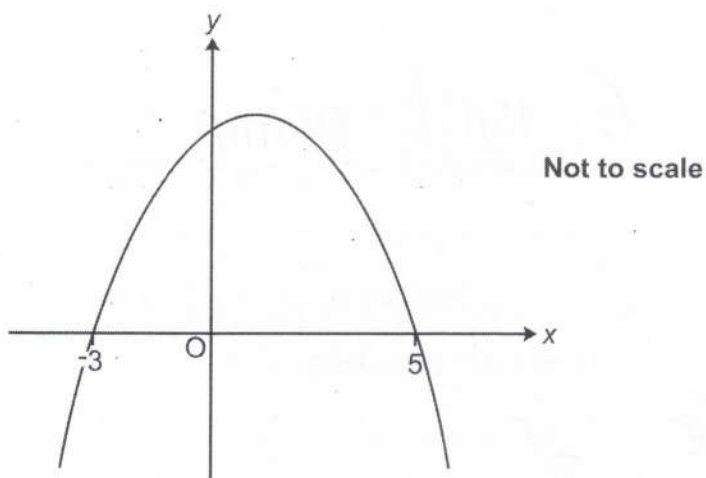

Frankie says

The y -intercept is 15.

(a) Show that what Frankie says could be correct.

[3]

$$y = (x+3)(x-5) \times -1$$

$$y = (x^2 + 3x - 5x - 15) \times -1$$

$$y = -x^2 + 2x + 15$$

$$c = 15$$

(b) Explain why what Frankie says may **not** be correct.

Equation could have a multiplier ✓

eg, $y = -k(x+3)(x-5)$ ✓

[c could = any multiple of 15] [2]

- 17 Blake is asked to write 15552000000 as a product of prime factors in index form.
Blake writes

$$15552000000 = 2^7 \times 5^6 \times 6^5.$$

- (a) Explain Blake's mistake.

6 isn't prime ✓

.....
.....
..... [1]

- (b) Write 15552000000 as a product of prime factors in index form.

$$2^7 \times 5^6 \times 2^5 \times 3^5$$

✓

(b) $2^{12} \times 3^5 \times 5^6$ ✓ [2]

- (c) You are given that $140000 = 2^5 \times 5^4 \times 7$.

Find the highest common factor (HCF) of 15552000000 and 140000.

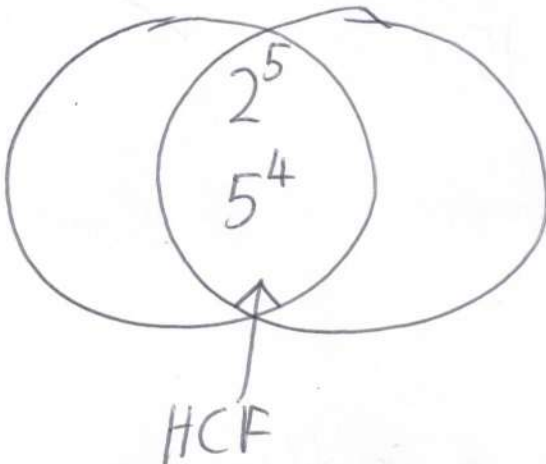

$$= 2^5 \times 5^4$$

✓

(c) $= 20,000$ ✓ [2]

18 The graph of $y = 2x + 1$ is drawn on this one centimetre grid.

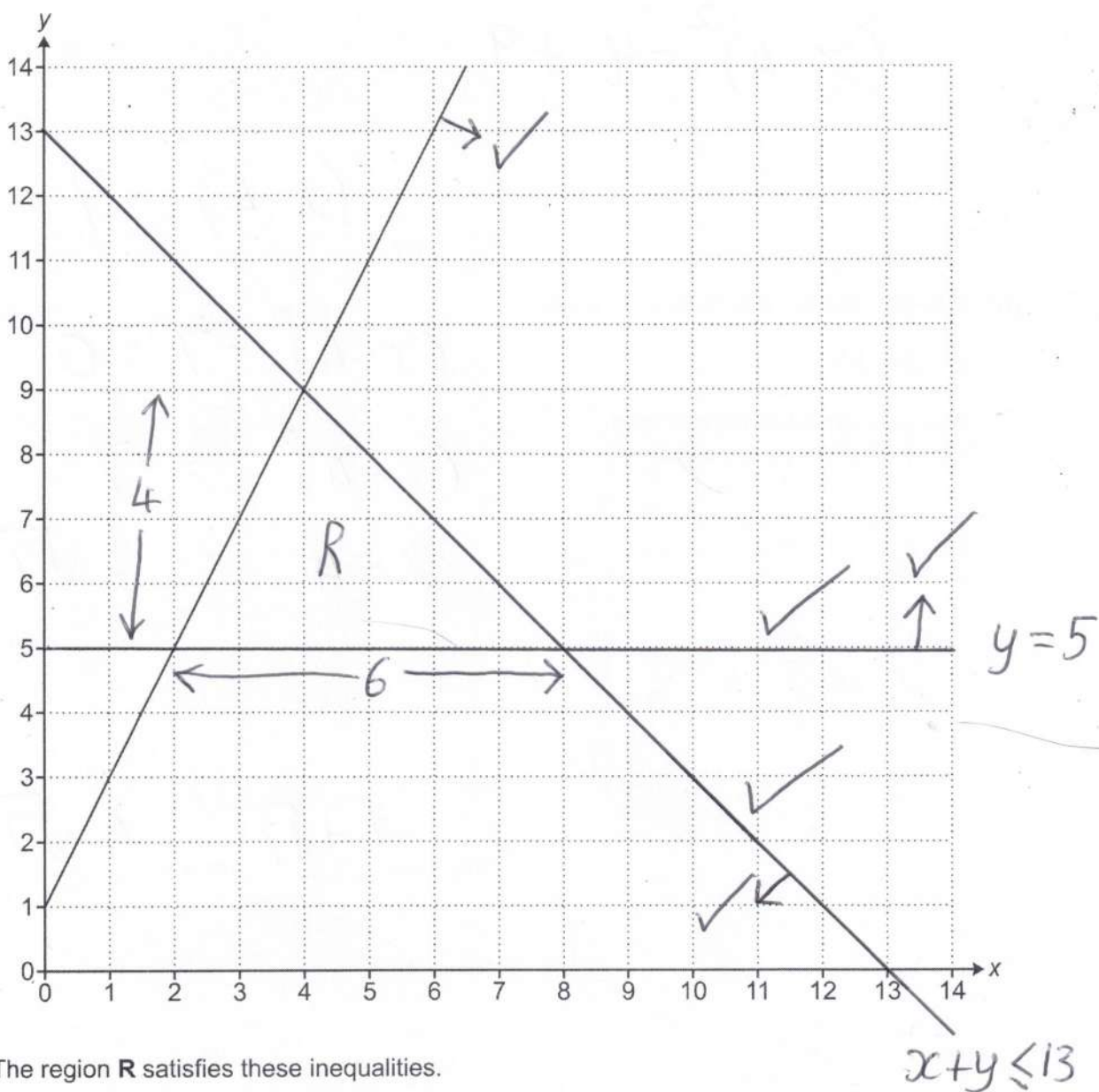

The region R satisfies these inequalities.

$$\begin{aligned} y &\leq 2x + 1 \\ y &\geq 5 \\ x + y &\leq 13 \end{aligned}$$

Show that the area of region R is 12cm^2 .

[6]

$$\begin{aligned} \text{Area} &= \frac{1}{2}bh \\ &= \frac{1}{2} \times 6 \times 4 = 12\text{cm}^2 \end{aligned}$$

- 19 (a) Write $x^2 - 8x + 9$ in the form $(x - a)^2 - b$.

$$(x-4)^2 - 16 + 9$$

✓

$$(a) \dots\dots\dots (x-4)^2 - 7 \dots\dots\dots [3]$$

✓
✓

- (b) Use your answer from part (a) to solve.

$$x^2 - 8x + 9 = 0$$

$$(x-4)^2 - 7 = 0$$

Give your answers in exact form.
You must show your working.

$$(x-4)^2 = 7$$

✓

$$x - 4 = \pm \sqrt{7}$$

$$(b) x = 4 + \sqrt{7} \dots\dots\dots \text{or } x = 4 - \sqrt{7} \dots\dots\dots [2]$$

✓

20 Two pyramids, A and B, are mathematically similar.

Pyramid A has surface area 12 cm^2 and volume 8 cm^3 .

Pyramid B has surface area 75 cm^2 .

Work out the volume of pyramid B.

You must show your working.

	A	B
SA	12	75

✓ 8

$$\text{Area scale factor} = \frac{75}{12} = \frac{25}{4} \quad \checkmark$$

$$\text{Linear sf} = \sqrt{\frac{25}{4}} = \frac{5}{2} \quad \checkmark$$

$$\text{Volume sf} = \left(\frac{5}{2}\right)^2 \quad \checkmark$$

$$\text{Vol B} = 8 \times \left(\frac{5}{2}\right)^3$$

125 ✓

..... cm^3 [4]

- 21 The diagram shows triangle ABC.
X lies on BC such that angle AXC = 90°.

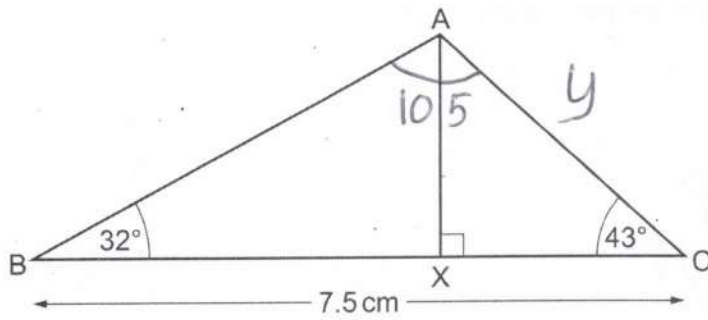

Not to scale

BC = 7.5 cm, angle ABC = 32° and angle ACB = 43°.

Work out length AX.
You must show your working.

$$\frac{y}{\sin 32} = \frac{7.5}{\sin 105} \times \sin 32 = 4.114...$$

m
✓
✓

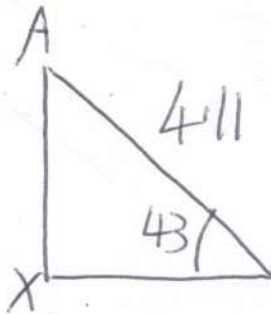

$$AX = \sin(43) \times 4.11 \checkmark \checkmark$$

$$= 2.806...$$

2.8 ✓

..... cm [6]

END OF QUESTION PAPER