

- 4 A theme park asked 900 people to choose their favourite activity from a list of five. The pictogram shows the results for four of the activities.

Thrill rides		250
Family rides		125
Entertainment		200
Children's rides		✓
Water rides		275

} 850 ✓

Key: represents 100 people

- (a) (i) How many people chose entertainment?

200 ✓
(a)(i) [1]

- (ii) How many **more** people chose water rides than family rides?

275 - 125 ✓
150 ✓
(ii) [2]

- (iii) All 900 people chose one of the five activities.

Complete the pictogram for children's rides. [3]

$900 - 850 = 50$ ✓

- (b) Will plays a game at the theme park. There are 20 cards numbered from 1 to 20. Will takes a card at random. He wins if the card he chooses shows a prime number.

Work out the probability that Will wins. Give your answer as a fraction in its simplest form.

2, 3, 5, 7, 11, 13, 17, 19 ✓✓
= $\frac{8}{20}$ ✓

$\frac{2}{5}$ ✓

(b) [4]

- (c) A family ticket for the theme park costs £68. If the ticket is bought online it costs 15% less.

How much does it cost to buy a family ticket online?

OR
10% = 6.8 ✓
5% = 3.4 ✓
10.2
68 × 0.85 ✓

68 - 10 - 0.2 = 57.80 ✓

(c) £ [3]

5 Simplify.

(a) $4a + 5a - 7a$

(a) $2a$ ✓ [1]

(b) $3g - 2f + 8g + 5f$

(b) $11g + 3f$ ✓ ✓ [2]

6 Write down the inequality shown on this number line.

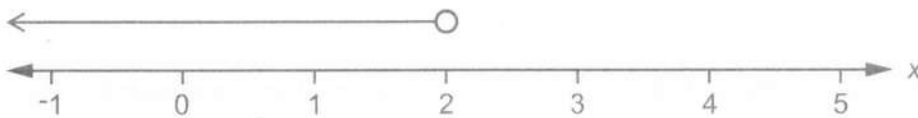

$x < 2$ ✓ ✓ [2]

7 Factorise fully.

(a) $6 + 9y$

(a) $3(3y + 2)$ ✓ [1]

(b) $2x^2 + 6x$

(b) $2x(x + 3)$ ✓ ✓ [2]

8 Plaza United are playing a football match away from home.

- (a) 379 supporters are going to the match by coach.
Each coach seats 45 people.

What is the smallest number of coaches that will be needed?

$$379 \div 45 = 8.4...$$

9 ✓

(a) [2]

- (b) In their last 50 matches, Plaza United have drawn 10 matches, lost 5 and won the rest.

Sam claims

The probability that Plaza United will win this match is 0.7.

- (i) Show calculations to support Sam's claim.

[2]

$$W = 50 - 10 - 5 = 35 \quad \checkmark$$

$$W = \frac{35}{50} = \frac{7}{10} = 0.7 \quad \checkmark$$

- (ii) Give one reason why Sam's claim may not be reliable.

Past results could be against
weaker teams / home /

injury to best players

[1]

- 9 Mr and Mrs Jones buy cinema tickets for themselves and their three children. The cost of an adult ticket is £6 more than a child ticket. The total cost of the **five** tickets is £45.

Work out the cost of an adult ticket.

$$\begin{array}{ccccc} C & C & C & A & A \\ x & x & x & x+6 & x+6 \end{array} \checkmark$$

$$5x + 12 = 45 \checkmark$$

$$5x = 33 \checkmark$$

$$\begin{aligned} x &= 33 \div 5 \\ &= 6.60 \checkmark \end{aligned} \quad \text{An adult ticket costs £} \underline{12.60} \checkmark \quad [5]$$

- 10 The area of the parallelogram is four times the area of the triangle.

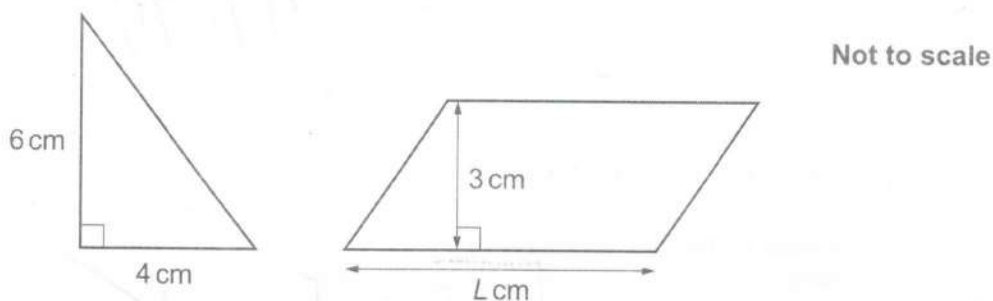

Calculate the length, L , of the parallelogram.

$$6 \times 4 = 24 \quad 24 \div 2 = 12 \checkmark \checkmark$$

$$12 \times 4 = 48 \quad \checkmark$$

$$48 \div 3 = 16 \checkmark$$

$$\underline{16} \checkmark$$

..... cm [5]

- 11 Harry has a job.
On Friday, he is paid £8.50 per hour.
On Saturday, he is paid $1\frac{1}{2}$ times that rate.

He works for 4 hours on Friday.

He works from 8 am until 1 pm on Saturday. = 5 ✓

How much does Harry earn in total for these two days?

(F)

$$8.50 \times 4$$

$$= \text{£}34 \quad \checkmark$$

(S)

$$8.5 \times 1.5 \times 5$$

$$= \text{£}63.75 \quad \checkmark$$

$$63.75 + 34 \quad \checkmark$$

$$= 97.75 \quad \checkmark$$

£..... [6]

- 12 The volume of a cube is 125 cm^3 .

Calculate the total surface area of the cube.
Give the units of your answer.

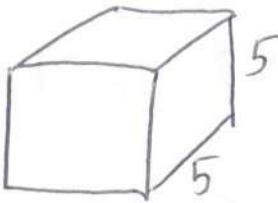

$$\sqrt{125} = 5 \quad \checkmark$$

$$5 \times 5 \times 6 \quad \checkmark$$

$$150 \quad \checkmark$$

$$\text{cm}^2 \quad \checkmark \quad [5]$$

Turn over

- 13 Here is a right-angled triangle.

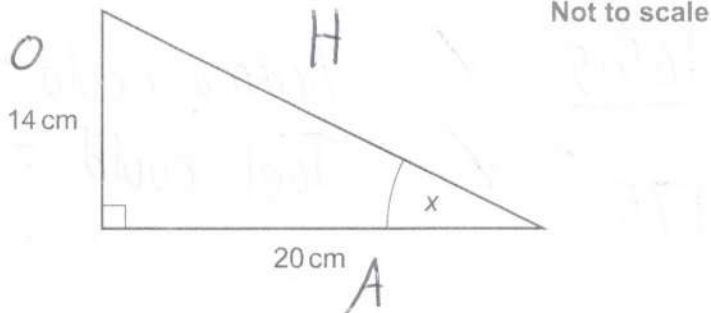

Show that angle x is 35° , correct to the nearest degree.

[3]



$$x = \tan^{-1} \left(\frac{14}{20} \right)$$

$$= 34.992\dots$$

$$= 35^\circ$$

- 14 Dean drives a distance of 760 km in 9 hours.
Robert drives a distance of 559 km in 6 hours 30 minutes.

Who has the highest average speed?
Show how you decide.



$$\text{Dean} = 760 \div 9 = 84.4$$

$$\text{Rob} = 559 \div 6.5 = 86$$

Robert

because

$$86 \text{ kph} > 84.4 \text{ kph}$$

[4]

- 15 Andrea is 165 cm tall, correct to the nearest cm.
Joel is 170 cm tall, correct to the nearest 10 cm.

Show that Andrea could be taller than Joel.

[3]

$$164.5 \leq \text{Andrea} < \underline{165.5} \quad \checkmark$$

$$\text{Andrea could} = 165.4$$

$$\underline{165} \leq \text{Joel} < 175 \quad \checkmark$$

$$\text{Joel could} = 165$$

✓ etc

- 16 Carol makes birthday cards.
Each card takes the same amount of time to make.

She makes 3 cards in 48 minutes.
She has an order for 80 cards.

Can she complete this order in 3 days if she works 8 hours each day?
Show how you decide.

$$3c = 48m \quad \checkmark$$

$$1c = 16m$$

$$80c = 16 \times 80 = 1280 \text{ mins} \quad \checkmark$$

$$3 \times 8 = 24 \text{ hrs} = 24 \times 60 \quad \checkmark$$

$$= 1440 \text{ mins} \quad \checkmark$$

Yes because the order takes 1280 mins, she has 1440 mins available. ✓ [5]

17 The table below shows the area, in square kilometres (km^2), of some countries.

Country	Area (km^2)
Australia	7.69×10^6
Latvia	6.46×10^4
Luxembourg	2.59×10^3
Russia	1.71×10^7
Singapore	7.24×10^2
Sweden	4.50×10^5

(a) Write the area of Sweden as an ordinary number.

(a) 450 000 ✓
..... km^2 [1]

(b) Which of the above countries has the smallest area?

(b) Singapore [1]

(c) Alexis says

The area of Australia is approximately three times larger than the area of Luxembourg.

Is she correct?
Show how you decide.

$$\frac{\text{Aus}}{\text{Lux}} = \frac{7.69 \times 10^6}{2.59 \times 10^3} = 2969 \dots \checkmark$$

Alexis is wrong because it is closer to being 3000 times bigger ✓
..... [2]

(d) Work out the total area of Russia and Australia.
Give your answer in standard form, correct to 2 significant figures.

$$(1.71 \times 10^7) + (7.69 \times 10^6) \checkmark$$

$$= \underline{24790000} \checkmark$$

(d) 2.5×10^7 ✓ ✓
..... km^2 [4]

- 18 Bob makes dry concrete by mixing cement, sand and stone in the ratio 1 : 2 : 3 by weight. He buys the cement, sand and stone in bags as shown in this table.

	Weight of bag (kg)	Cost per bag (£)
Cement	25	5.50
Sand	20	2.00
Stone	15	3.90

He packs the dry concrete into 30 kg bags.

$$50 \times 30 = 1500 \checkmark$$

Bob buys just enough cement, sand and stone to make 50 bags of dry concrete.

- (a) Show that Bob buys 500 kg of sand.

[3]

$$\begin{array}{ccc} C & Sa & St \\ 1 & 2 & 3 \end{array}$$

$$\text{Sand} = \frac{2}{6} \times 1500 = 500 \checkmark$$

- (b) Bob sells the 50 bags of dry concrete for a total of £396.

Calculate Bob's percentage profit.

$$\begin{array}{l} C = \frac{1}{6} \times 1500 = 250, \quad 250 \times 5.50 = \pounds 1375 \checkmark \\ \text{Sand} = \frac{500}{20} \times 2 = \pounds 50 \checkmark \\ St = \frac{3}{6} \times 1500 = 750, \quad \frac{750}{15} \times 3.9 = \pounds 195 \checkmark \end{array} \left. \begin{array}{l} \\ \\ \end{array} \right\} \pounds 300 \checkmark$$

$$\% \text{ profit} = \frac{96}{300} \times 100 = 32 \checkmark$$

(b) % [5]

(c) (i) Draw a line of best fit on the scatter diagram. ✓

[1]

(ii) Another student was absent for Test 2.
The student scored 40 marks on Test 1.

Use your line of best fit to estimate a result for this student on Test 2.

$\left[\begin{array}{c} 35 \\ \text{MS } \cancel{35} \rightarrow 44 \end{array} \right]$

(c)(ii)

39

[1]

(d) Work out the percentage of the 12 students whose result on Test 1 is **lower** than their result on Test 2.

$$\checkmark \frac{5}{12} \times 100$$

✓ ✓

41.7 ✓

(d)

% [4]

Turn over for Question 20

Turn over

20 (a) Are these two triangles definitely congruent?
Give a reason.

Not to scale

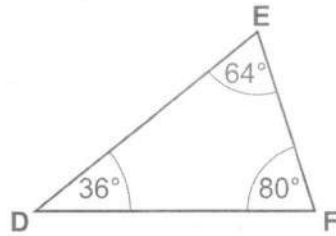
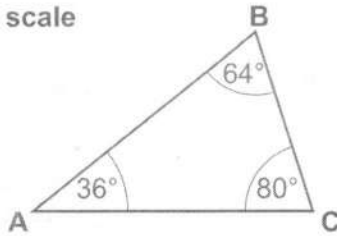

No because of unknown lengths ✓

[1]

(b) Prove that these two triangles are congruent.

Not to scale

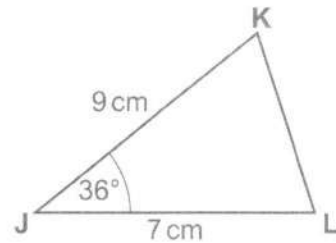
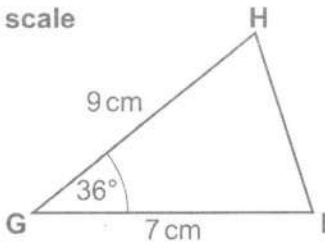

\checkmark $GH = JK$
 \checkmark $\angle HGI = \angle KJL$
 $GI = JL$

} SAS hence congruent. ✓

[3]

END OF QUESTION PAPER

OCR

Oxford Cambridge and RSA

Copyright Information

OCR is committed to seeking permission to reproduce all third-party content that it uses in its assessment materials. OCR has attempted to identify and contact all copyright holders whose work is used in this paper. To avoid the issue of disclosure of answer-related information to candidates, all copyright acknowledgements are reproduced in the OCR Copyright Acknowledgements Booklet. This is produced for each series of examinations and is freely available to download from our public website (www.ocr.org.uk) after the live examination series. If OCR has unwittingly failed to correctly acknowledge or clear any third-party content in this assessment material, OCR will be happy to correct its mistake at the earliest possible opportunity.

For queries or further information please contact The OCR Copyright Team, The Triangle Building, Shaftesbury Road, Cambridge CB2 8EA.

OCR is part of the Cambridge Assessment Group; Cambridge Assessment is the brand name of University of Cambridge Local Examinations Syndicate (UCLES), which is itself a department of the University of Cambridge.