

Answer ALL TWENTY FOUR questions.

Write your answers in the spaces provided.

You must write down all the stages in your working.

1 Here is a Venn diagram.

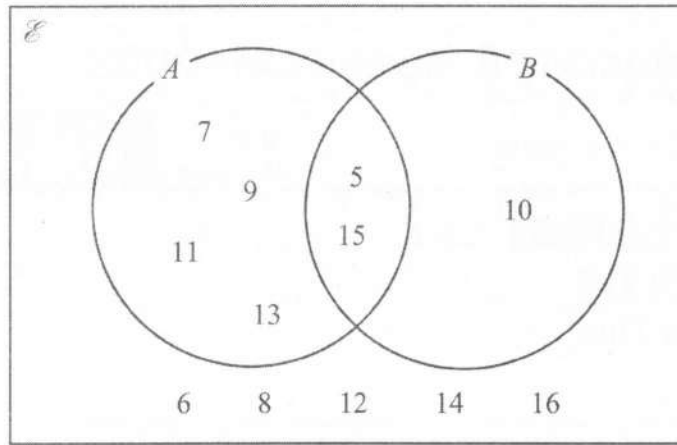

List the members of the set

(a) A

5, 7, 9, 11, 13, 15
(1)

(b) $A \cap B$

5, 15
(1)

(c) $(A \cup B)'$

6, 8, 12, 14, 16
(1)

(Total for Question 1 is 3 marks)

DO NOT WRITE IN THIS AREA

DO NOT WRITE IN THIS AREA

DO NOT WRITE IN THIS AREA



2 (a) Factorise fully $12pq - 18p$

$$6p(2q - 3)$$

(2)

There are 56 metal bars in a box.
Each metal bar is gold or silver or zinc.

y metal bars are gold.
 $(3y + 7)$ metal bars are silver.
 $(2y - 5)$ metal bars are zinc.

(b) Work out the number of metal bars that are zinc.
Show clear algebraic working.

$$\begin{aligned}y + 3y + 7 + 2y - 5 &= 56 \\6y + 2 &= 56 \\6y &= 54 \\y &= 9\end{aligned}$$

$$\text{Zinc} = 2 \times 9 - 5$$

13

(4)

(Total for Question 2 is 6 marks)



DO NOT WRITE IN THIS AREA

DO NOT WRITE IN THIS AREA

DO NOT WRITE IN THIS AREA

3 Joshua buys a car for \$12 500

He sells the car to Nina.

Nina pays

- a deposit of \$1500
- followed by 36 monthly payments of \$450

Work out Joshua's percentage profit.

$$1500 + 36 \times 450 = 17700$$

$$\frac{17700 - 12500}{12500} \times 100$$

41.6 %

(Total for Question 3 is 4 marks)



P 7 3 4 6 5 A 0 5 2 8

- 4 A biased spinner has three sections each of a different colour.

The table shows the probability that, when the spinner is spun once, it will land on blue or on orange or on white.

Colour	blue	orange	white
Probability	0.58	$2x$	x

- (a) Work out the value of x

$$\begin{aligned}3x + 0.58 &= 1 \\3x &= 0.42 \\x &= 0.14\end{aligned}$$

$$x = \frac{0.14}{(2)}$$

The spinner is spun 250 times.

- (b) Work out an estimate for the number of times the spinner will land on blue.

$$250 \times 0.58$$

$$\frac{145}{(2)}$$

(Total for Question 4 is 4 marks)



- 5 The diagram shows a shaded shape made from three identical semicircles, X , Y and Z

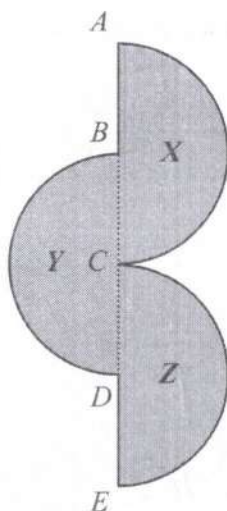

Diagram **NOT**
accurately drawn

$ABCDE$ is a straight line.

AC is the diameter of semicircle X and B is the centre of semicircle X
 BD is the diameter of semicircle Y and C is the centre of semicircle Y
 CE is the diameter of semicircle Z and D is the centre of semicircle Z

$$AC = BD = CE = 20 \text{ cm}$$

Work out the perimeter of the shaded shape.

Give your answer correct to the nearest whole number.

$$\text{Curved} = \frac{3}{2} \times \pi \times 20 = 30\pi$$

$$\begin{aligned} \text{Perimeter} &= 30\pi + AB + DE \\ &= 30\pi + 10 + 10 \\ &= 114.247\dots \end{aligned}$$

114

cm

(Total for Question 5 is 3 marks)



6 Juan wants to buy a ticket to fly from Madrid to Berlin.

He finds two different types of ticket he can buy in a sale, ticket A and ticket B

ticket A
 $\frac{1}{6}$ off normal price

ticket B
20% off normal price

The sale price of ticket A is 140 euros.

The sale price of ticket B is 136 euros.

Work out the difference between the normal price of ticket A and the normal price of ticket B

$$\textcircled{A} \quad \frac{5}{6} \times x = 140 \quad x = \frac{140}{5/6} = 168$$

$$\textcircled{B} \quad 0.8 \times y = 136 \quad y = \frac{136}{0.8} = 170$$

2

..... euros

(Total for Question 6 is 4 marks)



DO NOT WRITE IN THIS AREA

DO NOT WRITE IN THIS AREA

DO NOT WRITE IN THIS AREA

7 $A = 5^3 \times 7^3 \times 11^6$ and $B = 5^6 \times 7^2 \times 11^4$

Find the highest common factor (HCF) of A and B
Give your answer as a product of powers of its prime factors.

$$5^3 \times 7^2 \times 11^4$$

(Total for Question 7 is 2 marks)



P 7 3 4 6 5 A 0 9 2 8

8 (a) Solve the inequality $8x - 4 \geq 3x - 10$

$$5x - 4 \geq -10$$

$$5x \geq -6$$

$$x \geq -1.2$$

$$\text{or } x \geq -\frac{6}{5}$$

(2)

The region **R**, shown shaded in the diagram, is bounded by three straight lines.

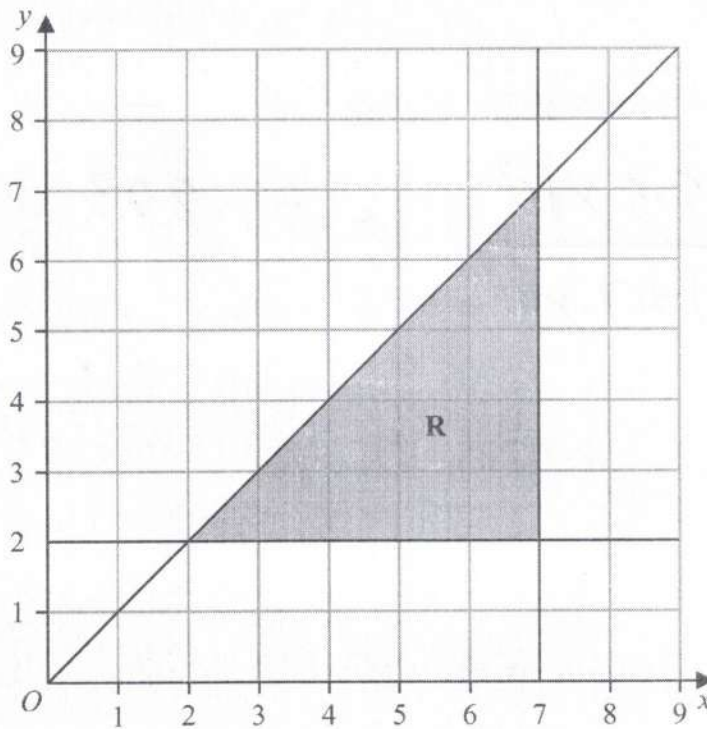

(b) Write down the three inequalities that define the region **R**

$$y \geq 2$$

$$x \leq 7$$

$$y \leq x$$

(3)

(Total for Question 8 is 5 marks)



- 9 (a) Write 5.87×10^{-4} as an ordinary number.

0.000587

(1)

- (b) Write 84 000 000 in standard form.

8.4×10^7

(1)

The number of neurons in a human brain is 8.5×10^{10}

The number of neurons in a monkey brain is 1.47×10^9

The number of neurons in a human brain is $K \times$ the number of neurons in a monkey brain.

- (c) Work out the value of K
Give your answer correct to one decimal place.

$$K = \frac{8.5 \times 10^{10}}{1.47 \times 10^9} = 57.823\dots$$

57.9

$K =$
(2)

(Total for Question 9 is 4 marks)



10 Here is triangle ABC

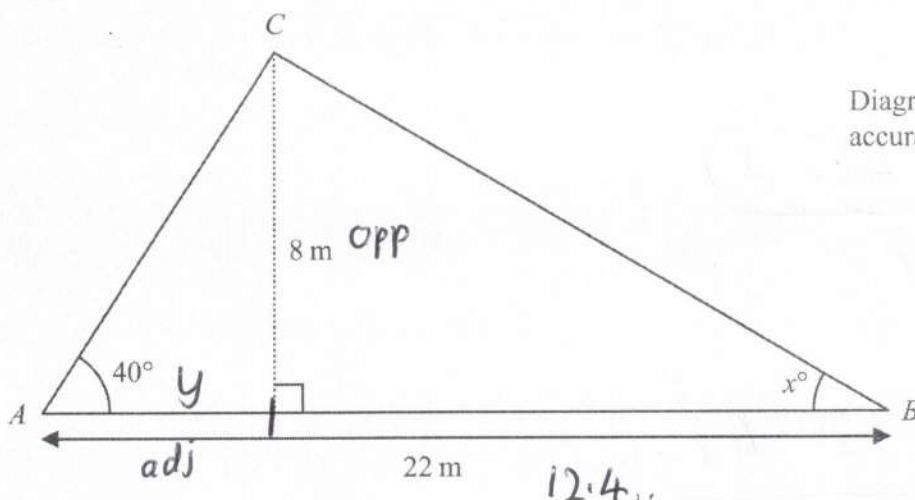

Work out the value of x
 Give your answer correct to one decimal place.
 Show your working clearly.

T°A $y = \frac{8}{\tan 40} = 9.534\dots$

T°A $x = \tan^{-1}\left(\frac{8}{12.465\dots}\right)$
 $= 32.6901\dots$

$x = 32.7$

(Total for Question 10 is 5 marks)



DO NOT WRITE IN THIS AREA

DO NOT WRITE IN THIS AREA

DO NOT WRITE IN THIS AREA

11 Express $\frac{3}{4} + \frac{5-x}{6x}$ as a single fraction in its simplest terms.

$$= \frac{18x + 4(5-x)}{24x}$$

$$= \frac{18x + 20 - 4x}{24x}$$

$$\frac{14x + 20}{24x}$$

(Total for Question 11 is 3 marks)

$$= \frac{7x + 10}{12x}$$



12 (a) Complete the table of values for $y = x^3 - 3x + 1$

x	-2	-1	0	1	2
y	-1	3	1	-1	3

(2)

(b) On the grid, draw the graph of $y = x^3 - 3x + 1$ for values of x from -2 to 2

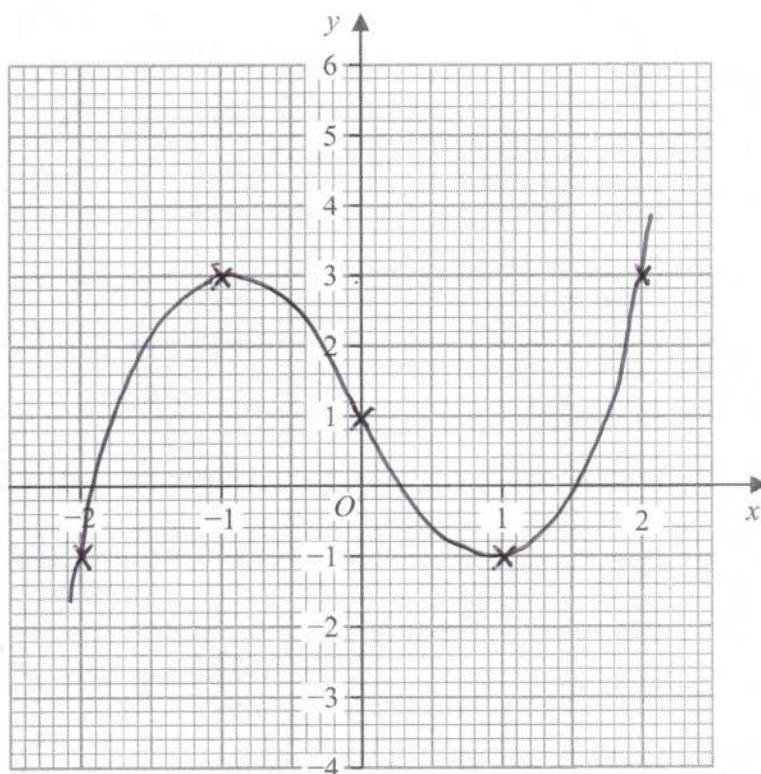

(2)

DO NOT WRITE IN THIS AREA

DO NOT WRITE IN THIS AREA

DO NOT WRITE IN THIS AREA



Here are four graphs.

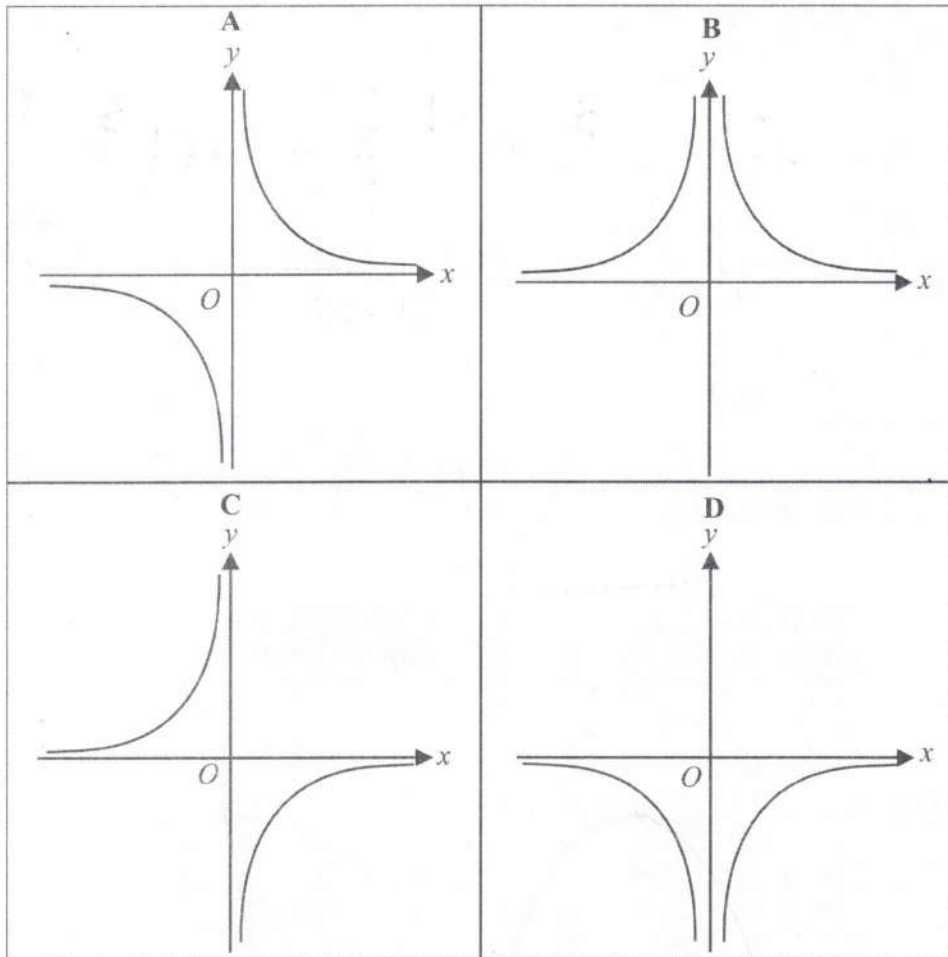

(c) Write down the letter of the graph that could have the equation $y = -\frac{1}{x^2}$

D

(1)

(Total for Question 12 is 5 marks)



P 7 3 4 6 5 A 0 1 5 2 8

DO NOT WRITE IN THIS AREA

DO NOT WRITE IN THIS AREA

DO NOT WRITE IN THIS AREA

- 13 The cumulative frequency graph gives information about the times, in seconds, that 80 adults took to log in to an online bank.

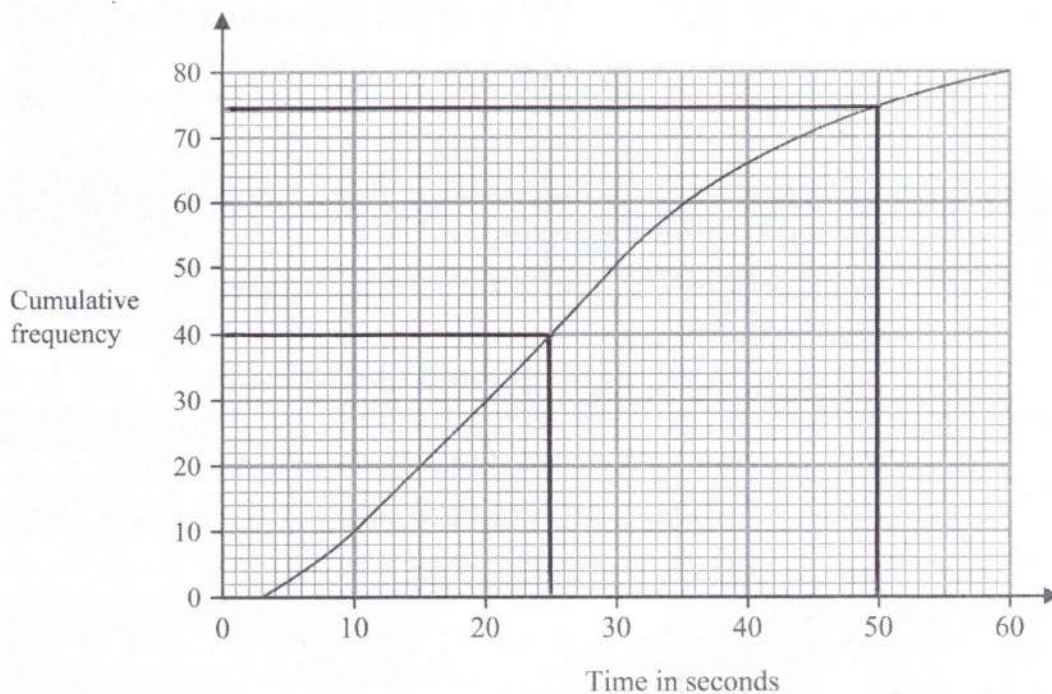

- (a) Find an estimate for the median time.

25

seconds

(1)

- (b) Work out the percentage of these adults that took longer than 50 seconds to log in. Show your working clearly.

$$\frac{5}{80} \times 100 \quad \text{or} \quad \frac{6}{80} \times 100$$

6.25%

7.5%

[ms 5 → 7.5]

%

(3)

(Total for Question 13 is 4 marks)



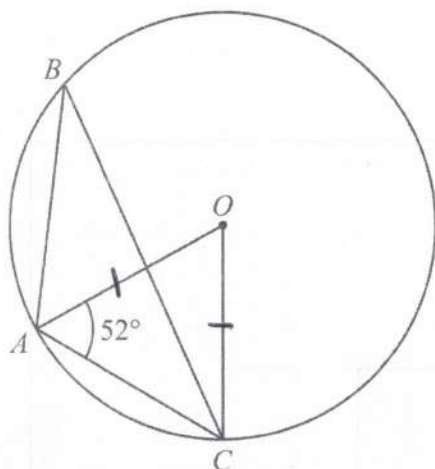

Diagram NOT
accurately drawn

A , B and C are points on a circle, centre O

Angle $OAC = 52^\circ$

Find the size of angle ABC

Give reasons for your working.

$$OA = OC = \text{radii}$$

$$\angle OCA = 52 \text{ (base angles of isosceles triangle are equal)}$$

$$\angle AOC = 76 \text{ (angles in a triangle sum to } 180)$$

$$\angle ABC = 76 \div 2 = 38^\circ \text{ (angle at centre is twice the angle at circumference)}$$

38

(Total for Question 14 is 3 marks)



15 Make n the subject of the formula $x = \frac{3p+n}{3n-4}$

$$x(3n-4) = 3p+n$$

$$3xn - 4x = 3p+n$$

$$3xn - n = 3p + 4x$$

$$n(3x-1) = 3p + 4x$$

$$n = \frac{3p+4x}{3x-1}$$

(Total for Question 15 is 3 marks)

DO NOT WRITE IN THIS AREA

DO NOT WRITE IN THIS AREA

DO NOT WRITE IN THIS AREA



DO NOT WRITE IN THIS AREA

16 A curve has equation $y = 4x^3 - 8x + 5$

Find the x coordinates of the two points on the curve where the gradient is $\frac{1}{3}$

$$\frac{dy}{dx} = 12x^2 - 8 = \frac{1}{3}$$

$$36x^2 - 24 = 1$$

$$36x^2 = 25$$

$$x^2 = \frac{25}{36}$$

$$x = \sqrt{\frac{25}{36}}$$

$$\pm \frac{5}{6}$$

(Total for Question 16 is 4 marks)



P 7 3 4 6 5 A 0 1 9 2 8

DO NOT WRITE IN THIS AREA

DO NOT WRITE IN THIS AREA

DO NOT WRITE IN THIS AREA

17 The histogram gives information about the weights, in grams, of some oranges in a box.

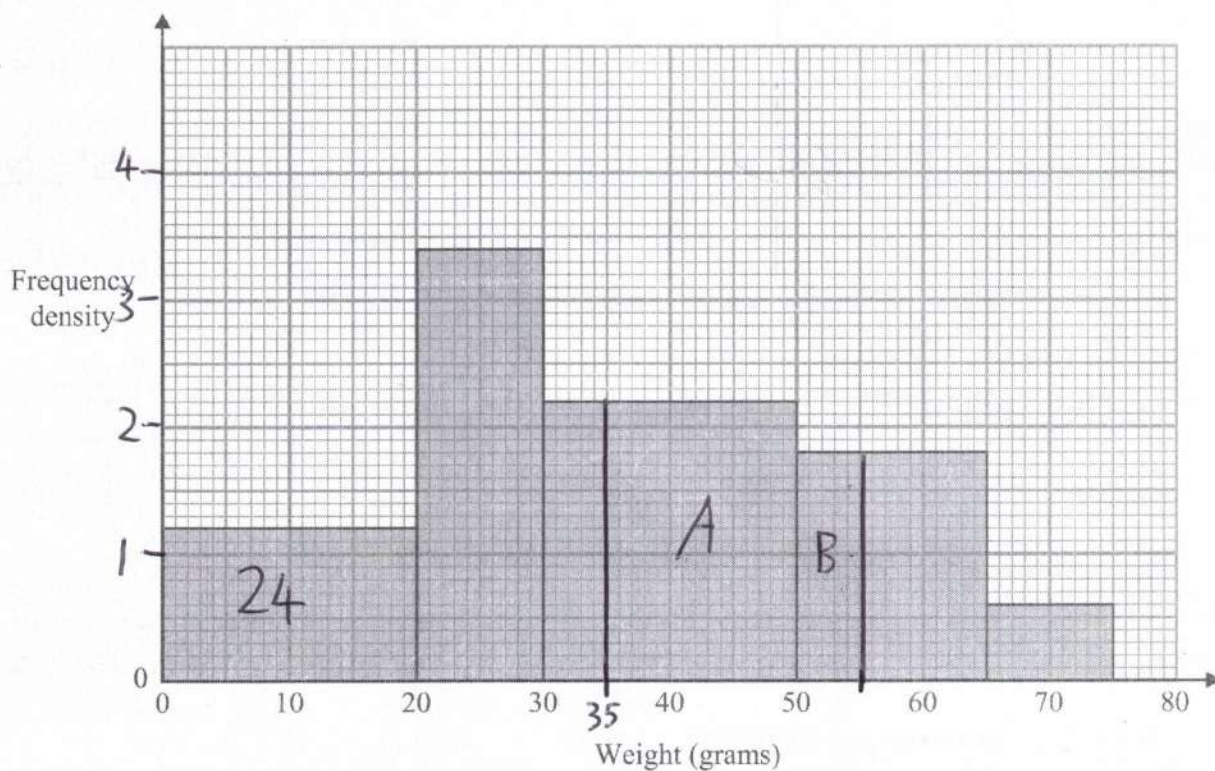

24 of these oranges weigh less than 20 grams.

Medium oranges weigh between 35 grams and 55 grams.

Work out an estimate for the number of medium oranges in the box.

$$24 \div 20 = 1.2$$

$$A = 15 \times 2.2 = 33$$

$$B = 5 \times 1.8 = 9$$

$$33 + 9 = 42$$

(Total for Question 17 is 3 marks)



18 The diagram shows the positions of three villages, A , B and C

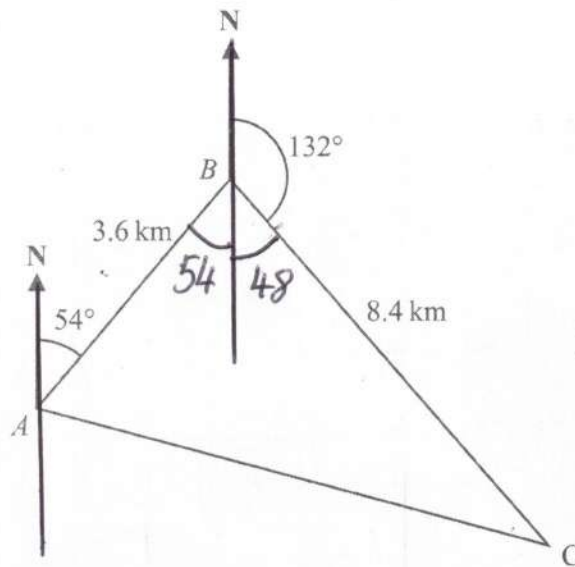

Diagram NOT
accurately drawn

The bearing of B from A is 054°

The bearing of C from B is 132°

Melur walks from A to B

She then walks from B to C and from C to A

Melur walks at an average speed of 6 km/h

Work out the total time Melur takes.

Give your answer in hours and minutes.

$$AC^2 = 3.6^2 + 8.4^2 - 2 \times 3.6 \times 8.4 \times \cos 102$$

$$AC = \sqrt{96.094\dots} = 9.802\dots \text{ km}$$

$$\text{Time} = \frac{9.802 + 3.6 + 8.4}{6} = 3.6337\dots$$

3 hours 38 minutes

(Total for Question 18 is 5 marks)



19 Here are the first 4 terms in an arithmetic sequence.

3 7 11 15

The last term of the sequence is x

The sum of the terms of the sequence is 7260

Find the value of x

Show clear algebraic working.

$$a = 3$$

$$d = 4$$

$$\begin{aligned}x &= a + (n-1)d &= 3 + 4(n-1) \\ & &= 4n - 1\end{aligned}$$

$$S_n = \frac{n}{2} [2 \times 3 + (n-1) \times 4] = 7260$$

$$= 6n + 4n^2 - 4n = 14520$$

$$2n^2 + n - 7260 = 0$$

$$n = \frac{-1 \pm \sqrt{1 + 58080}}{4}$$

(reject negative)

$$n = 60$$

$$x = 4 \times 60 - 1$$

$$x = 239$$

(Total for Question 19 is 6 marks)

DO NOT WRITE IN THIS AREA

DO NOT WRITE IN THIS AREA

DO NOT WRITE IN THIS AREA



20 A bag contains only 10 cent coins and 20 cent coins.

Josip takes at random a coin from the bag, records its value and replaces it in the bag. He then takes at random a second coin from the bag, records its value and replaces it in the bag.

Josip finds the mean value of the two coins.

The probability that the two coins have a mean value of 10 cents is $\frac{49}{121}$

Work out the probability that the two coins have a mean value of 15 cents.

$$\begin{array}{cc} 10c & 20c \\ x & 1-x \end{array}$$

$$P(10c, 10c) = x \times x = \frac{49}{121}$$

$$x = \frac{7}{11}$$

$$P(10c, 20c) = 2 \times \frac{7}{11} \times \frac{4}{11}$$

$$\frac{56}{121}$$

(Total for Question 20 is 4 marks)



21 Here is a triangular prism $ABCDEF$

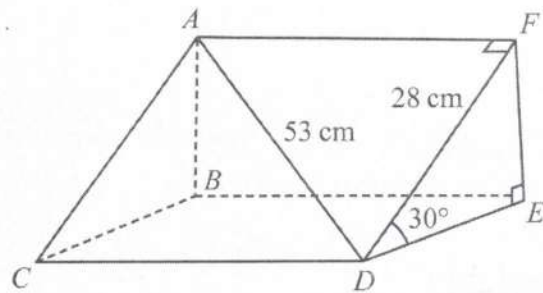

Diagram NOT accurately drawn

$AD = 53$ cm
 $DE = 28$ cm
 Angle $FDE = 30^\circ$

Work out the volume of the triangular prism.
 Give your answer correct to the nearest whole number.

$$AF = \sqrt{53^2 - 28^2} = 45$$

$$EF = 28 \times \sin 30 = 14$$

$$DE = 28 \times \cos 30 = 14\sqrt{3}$$

$$\text{Vol} = \frac{1}{2}bh \times \text{length}$$

$$= \frac{1}{2} \times 14\sqrt{3} \times 14 \times 45$$

$$= 7638.34$$

7638 cm³

(Total for Question 21 is 5 marks)



DO NOT WRITE IN THIS AREA

DO NOT WRITE IN THIS AREA

DO NOT WRITE IN THIS AREA

22 [In this question 1 cm = 1 unit on the x -axis and 1 cm = 1 unit on the y -axis]

P is a point on a circle with centre $(0, 0)$
The coordinates of P are $(8, -10)$

The line L is the tangent to the circle at the point P
 L crosses the x -axis at the point Q and crosses the y -axis at the point R

Work out the length of RQ
Give your answer correct to 3 significant figures.

$$\text{radius} = \sqrt{8^2 + 10^2} = 2\sqrt{41}$$

$$m_{\text{radius}} = -\frac{10}{8} = -\frac{5}{4}$$

$$m_{\text{tangent}} = \frac{4}{5} \quad \text{use } x=8, y=-10$$

$$y = mx + c$$

$$-10 = \frac{4}{5} \times 8 + c$$

$$c = -\frac{82}{5}$$

$$y = \frac{4}{5}x - \frac{82}{5}$$

x -axis, $y=0$

$$\text{so } x = \frac{41}{2}$$

y -axis, $x=0$

$$\text{so } y = -\frac{82}{5}$$

$$\begin{aligned} RQ &= \sqrt{\left(\frac{41}{2}\right)^2 + \left(\frac{82}{5}\right)^2} \\ &= 26.2528... \\ &= 26.3 \text{ cm} \end{aligned}$$

(Total for Question 22 is 6 marks)



P 7 3 4 6 5 A 0 2 5 2 8

23 Solid A is similar to solid B

Here is some information about solid A and solid B

	solid A	solid B
Height (cm)	3^x	
Area (cm ²)	7776	486
Volume (cm ³)	8^x	2^{x+4}

Work out the height of solid B
Give your answer as a decimal.

$$\text{Surface area scale factor} = \frac{7776}{486} = 16$$

$$\text{Linear scale} = \sqrt{16} = 4$$

$$\text{Volume scale} = 4^3 = 64$$

so (Vol)

$$2^{x+4} \times 64 = 8^x$$

$$2^{x+4} \times 2^6 = (2^3)^x$$

$$2^{x+10} = 2^{3x}$$

$$x+10 = 3x$$

$$x = 5$$

$$\text{Height of B} = 3^5 \div 4 = 60.75$$



23 Solid A is similar to solid B

Here is some information about solid A and solid B

	solid A	solid B
Height (cm)	3^x	
Area (cm ²)	7776	486
Volume (cm ³)	8^x	2^{x+4}

Work out the height of solid B
Give your answer as a decimal.

$$\text{Surface area scale factor} = \frac{7776}{486} = 16$$

$$\text{Linear scale} = \sqrt{16} = 4$$

$$\text{Volume scale} = 4^3 = 64$$

so (Vol)

$$2^{x+4} \times 64 = 8^x$$

$$2^{x+4} \times 2^6 = (2^3)^x$$

$$2^{x+10} = 2^{3x}$$

$$x+10 = 3x$$

$$x = 5$$

$$\text{Height of B} = 3^5 \div 4 = 60.75$$



24 The curve with equation $f(x) = 5x^2 + 9x + 2$ is transformed to the curve with equation

$$g(x) = 5(x+4)^2 + 9(x+4) + 8 \text{ by the translation } \begin{pmatrix} a \\ b \end{pmatrix}$$

(a) Write down the value of a and the value of b

$(x) \rightarrow (x+4)$
 $\leftarrow 4$

$\left. \begin{matrix} +2 \\ +8 \end{matrix} \right\} +6$

$a = \underline{\quad -4 \quad}$
 $b = \underline{\quad 6 \quad}$

(2)

The graph of $y = p \cos(x+q)^\circ$ for $0 \leq x \leq 360$ is drawn on the grid below.

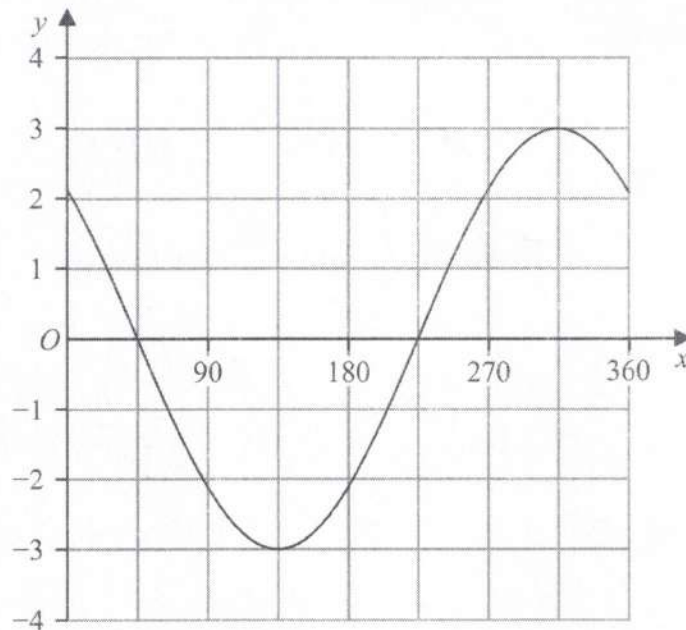

Given that $p > 0$ and $0 < q < 360$

(b) find the value of p and the value of q

$\updownarrow sf = 3$

$\leftarrow 45^\circ$

$p = \underline{\quad 3 \quad}$
 $q = \underline{\quad 45 \quad}$

(2)

(Total for Question 24 is 4 marks)

TOTAL FOR PAPER IS 100 MARKS

